

*Direct Drive
Technology*

SKA DDL

*IRON CORE
LINEAR MOTORS*



Copyright © 2007 Motor Power Company. All rights reserved. Contents are subjected to change without any notice. Edition 05/08

motor
technology
control in motion.com

**MOTOR
POWER
COMPANY**

SKA DDL LINEAR MOTOR

Precision, dynamics, performance for the cutting-edge technology in motion control: this is the core prerogative of the direct drive series by Motor Power Company. Our linear and torque motors, available in different modular solutions, respond to the most challenging applications and to your machine integration needs.

The SKA direct drive linear motors are synchronous linear permanent magnet motors created with "iron core" technology. Two versions proposed by Motor Power Company: the Frameless version -includes the moving coil, with embedded temperature sensor and magnetic track- and the Linear Stage version -features moving coil, temperature sensor and magnetic track assembled on a basement with moving coil, linear ball bearings, linear guides, bellows, encoder, cables and cable carrier-.

- 40N to 2400N continuous force (134.8N to 7200N peak force)
- 5 m/s speed
- 5g (50m/s²) acceleration
- Feedback options: optical or magnetic Sin Cos, TTL and absolute encoder, Hall Sensor.

All SKA motors feature advantages of Direct Drive technology:

replacing all transmission mechanical components (like gearboxes, screws, belts, pulleys, racks) • bypass the limits given by backlash, friction and inertia • enhance manufactured throughput and reliability • improve motion linearity and precision • decrease noise levels • distribute power and motion control intelligence in the machine • simplify and accelerate the design and assembly of the machine • save energy in machine operation • reduce costs.

	SKA DDL	30.40	30.80	50.75	50.150	55.275	55.550	75.660	75.990	100.1200	100.1600	125.2000	150.2400
Peak force	(N)	134.8	269.5	247	495	825	1650	1980	2970	3600	4800	6000	7200
Continuous force	(N)	40	80	75	150	275	550	660	990	1200	1600	2000	2400
Magnetic attraction	(N)	260	520	430	860	1202	2405	3143	4663	5831	7774	9829	11790
Speed	(m/s)	5	5	5	5	5	5	5	5	5	5	5	5
Acceleration	(m/s ²)	50	50	50	50	50	50	50	50	50	50	50	50
Coil lenght	(mm)	102	186	102	186	186	354	354	522	522	690	690	690
Coil width	(mm)	56	56	76	76	80	80	100	100	125	125	150	175
Coil height	(mm)	23	23	23	23	47.5	47.5	47.5	47.5	47.5	47.5	47.5	47.5
Coil weight	(Kg)	0.55	1	0.8	1.6	3	7	10	14	18	25	31	38
Magnet track width	(mm)	50	50	70	70	90	90	120	120	140	140	175	200
Magnet track height	(mm)	10.8	10.8	10.8	10.8	14.8	14.8	14.8	14.8	14.8	14.8	14.8	14.8
Magnet track weight	(Kg/m)	3.3	3.3	5	5	9.1	9.1	12.2	12.2	14.6	14.6	18	21.4

Data are rated at ΔT = 80°C , 0-40°C environmental temperature - Class F insulation. Performances are rated with natural ventilation

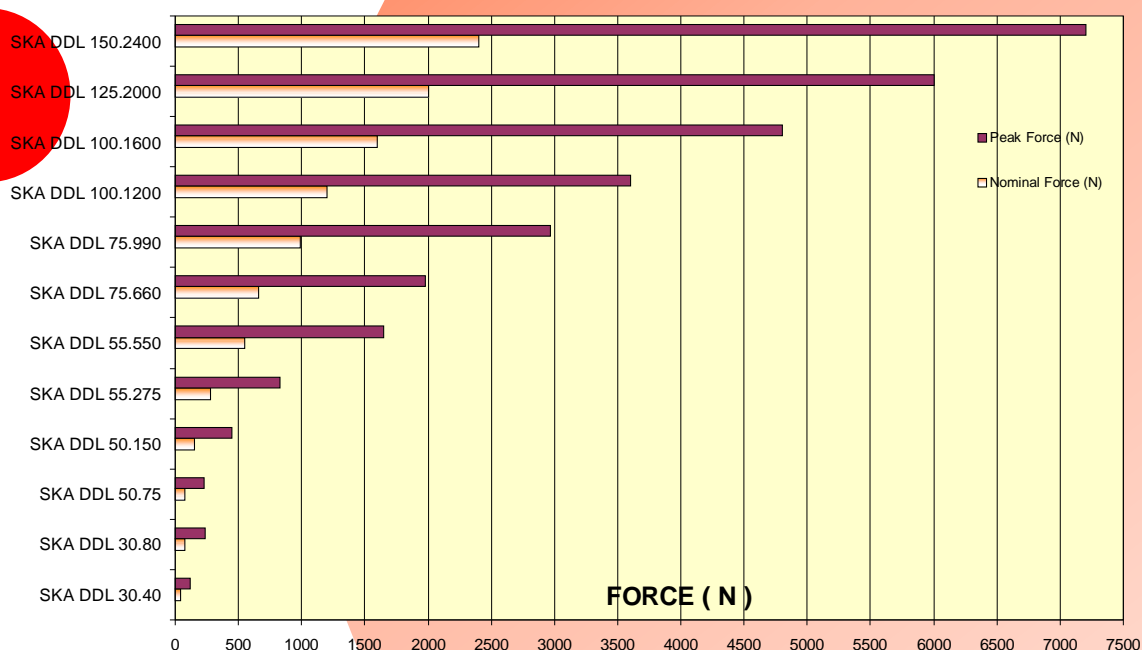

How to order SKA DDL *LINEAR STAGE VERSION*

SKA DDL LS 55.275 17 500 00 007 01 XXXX

Series name	Motor version	Force	Winding	Stroke	Hall Sensors	Feedback	Connectors	Internal code
	LS= Linear stage	55.275 55.550 75.660 75.990 100.1200 100.1600 125.2000 150.2400	Consult data sheet	Consult data sheet	00 Without Hall Sensor 01 With Hall Sensor	000 No encoder 006 TTL magnetic encoder 2 μm/P 2mm 007 TTL magnetic encoder 10 μm/P 2mm 008 TTL optical encoder 5 μm/P 200μm 015 Sin-Cos optical encoder P 40μm 019 TTL optical encoder 1 μm/P 200μm 021 Sin-Cos optical encoder P 200μm 023 Sin-Cos magnetic encoder P 2mm 024 TTL magnetic encoder 1 μm/P 2mm 025 TTL optical encoder 0,5 μm/P 40μm 026 TTL optical encoder 1 μm/P 40μm 027 TTL optical encoder 2 μm/P 40μm 028 TTL optical encoder 10 μm/P 200μm 030 Sin-Cos magnetic encoder P 1mm 031 TTL magnetic encoder 0,2 μm/P 1mm 032 TTL magnetic encoder 1 μm/P 1mm 033 TTL magnetic encoder 2 μm/P 1mm 034 TTL magnetic encoder 5 μm/P 1mm	01 Double Connector 02 Double Cable gandle 03 Free cable	Internal use only

- 1 Moving coil
- 2 Protection cover
- 3 Basement
- 4 Stroke stopper
- 5 Rubber bumpers
- 6 Magnet track
- 7 Connectors
- 8 Cable carrier chain with dynamic laying cables

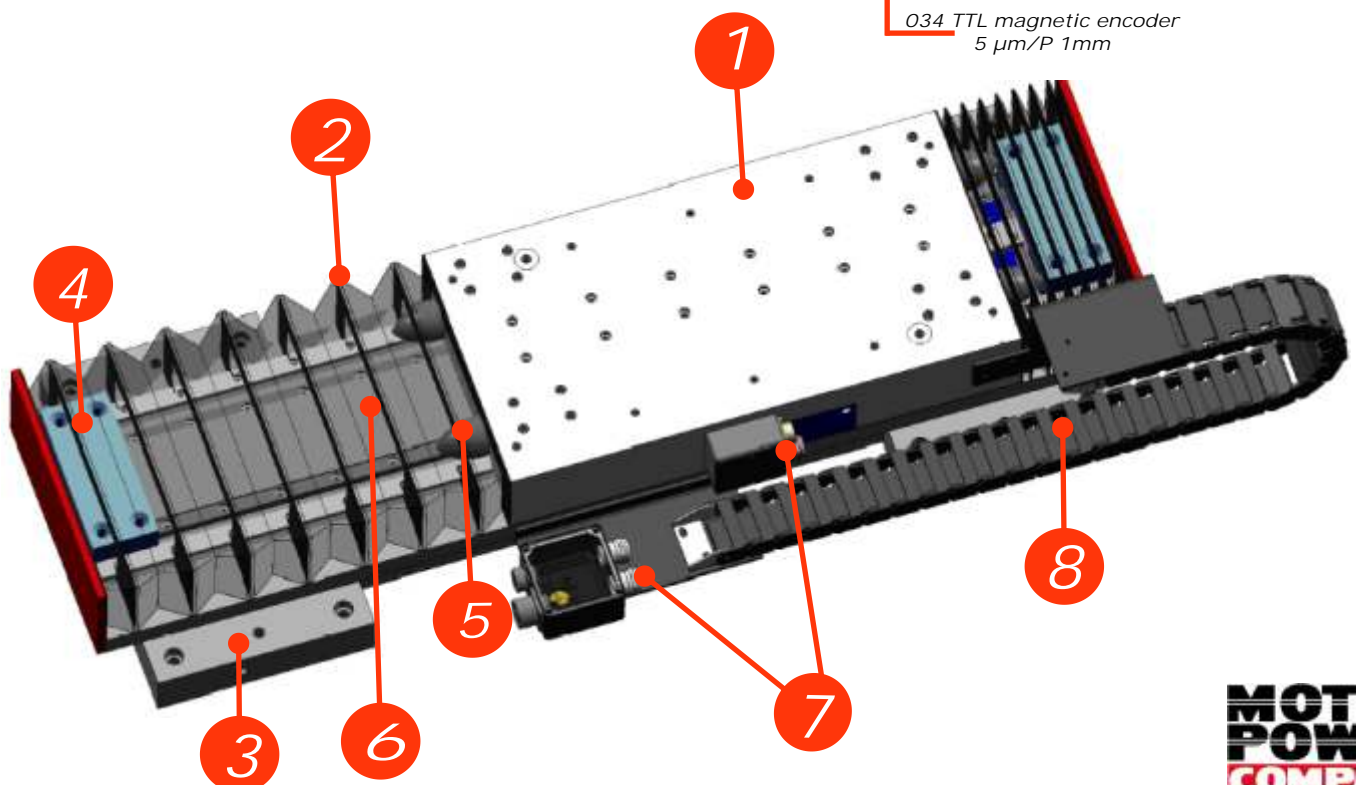

How to order SKA DDL *FRAMELESS VERSION*

SKA DDL	MC	XX	30.80	15	XXX	01	03	XXX
Series name	Motor version	Internal code	Type.Force	Winding	Internal code	Hall Sensors	Connections	Internal code
	MC= Moving Coil	Internal use only	<ul style="list-style-type: none"> — 30.40 — 30.80 — 50.70 — 50.150 — 55.275 — 55.550 — 75.660 — 75.990 — 100.1200 — 100.1600 — 125.2000 — 150.2400 	Consult data sheet	Internal use only	<ul style="list-style-type: none"> — 00 Without Hall Sensor — 01 With Hall Sensor, 500 mm cable included 	<ul style="list-style-type: none"> — 03 500 mm free cable 	Internal use only

SKA DDL	MT	XX	30	480	XX
Series name	Motor version	Internal code	Type	Length	Internal code
	MT= Magnet Track	Internal use only	<ul style="list-style-type: none"> — 30 — 50 — 55 — 75 — 100 — 125 — 150 	<ul style="list-style-type: none"> — 120 — 240 — 480 	Internal use only

- ① Moving coil
- ② Magnet track
- ③ Embedded Hall Sensor Slot

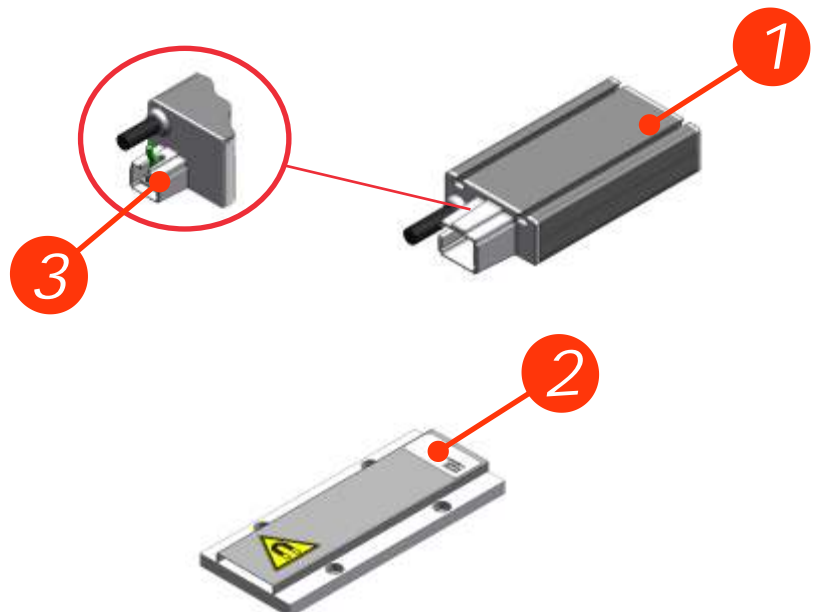

SERIES

SKA DDL

TRANSDUCER SERIES PAGE 1

TRANSDUCERS

TTL OPTICAL ENCODER P200 μ m (FEEDBACK ORDER NR. 008 - 019 - 028)

RATED VOLTAGE	Vn	[Vdc]	5 \pm 5%
RATED CURRENT	In	[mA]	120
MAX OUTPUT FREQUENCY	F	[MHz]	5
WORKING TEMPERATURE	Tn	[°C]	0° \div + 50°
ELECTRONIC TYPE			LINE DRIVER AM 26 LS32
ZERO PULSE			STANDARD
RESOLUTION	R	[μ m]	1 - 5 - 10
ACCURACY	A	[μ m]	\pm 30 μ m/m
OPTICAL LINE PITCH	P	[μ m]	200
MAX SPEED	S	[m/s]	It depends of resolution

SIN COS OPTICAL ENCODER P200 μ m (FEEDBACK ORDER NR. 021)

RATED VOLTAGE	Vn	[Vdc]	5 \pm 5%
RATED CURRENT	In	[mA]	120
MAX OUTPUT FREQUENCY	F	[kHz]	50
WORKING TEMPERATURE	Tn	[°C]	0° \div + 50°
SIGNAL TYPE		[Vdc]	1 Vpp
ZERO PULSE			STANDARD
RESOLUTION	R	[μ m]	Function of the interpolator
ACCURACY	A	[μ m]	\pm 30 μ m/m
OPTICAL LINE PITCH	P	[μ m]	200
MAX SPEED	S	[m/s]	It depends of interpolator

TTL OPTICAL ENCODER P40 μ m (FEEDBACK ORDER NR. 025 - 026 - 027)

RATED VOLTAGE	Vn	[Vdc]	5 \pm 5%
RATED CURRENT	In	[mA]	120
MAX OUTPUT FREQUENCY	F	[MHz]	5
WORKING TEMPERATURE	Tn	[°C]	0° \div + 50°
ELECTRONIC TYPE			LINE DRIVER AM 26 LS32
ZERO PULSE			STANDARD
RESOLUTION	R	[μ m]	0.5 - 1 - 2
ACCURACY	A	[μ m]	\pm 5 μ m/m
OPTICAL LINE PITCH	P	[μ m]	40
MAX SPEED	S	[m/s]	It depends of resolution

SIN COS OPTICAL ENCODER P40 μ m (FEEDBACK ORDER NR. 015)

RATED VOLTAGE	Vn	[Vdc]	5 \pm 5%
RATED CURRENT	In	[mA]	120
MAX OUTPUT FREQUENCY	F	[kHz]	250
WORKING TEMPERATURE	Tn	[°C]	0° \div + 50°
SIGNAL TYPE		[Vdc]	1 Vpp
ZERO PULSE			STANDARD
RESOLUTION	R	[μ m]	Function of the interpolator
ACCURACY	A	[μ m]	\pm 5 μ m/m
OPTICAL LINE PITCH	P	[μ m]	40
MAX SPEED	S	[m/s]	It depends of interpolator

SERIES

SKA DDL

TRANSDUCER SERIES PAGE 2

TRANSDUCERS

TTL MAGNETIC ENCODER P2mm (FEEDBACK ORDER NR. 006 - 007 - 024)			
RATED VOLTAGE	Vn	[Vdc]	5 ± 2.5%
RATED CURRENT	In	[mA]	200
MAX OUTPUT FREQUENCY	F	[kHz]	500
WORKING TEMPERATURE	Tn	[°C]	0° ÷ + 50°
ELECTRONIC TYPE			LINE DRIVER AM 26 LS32
ZERO PULSE			STANDARD
RESOLUTION	R	[μm]	1 - 2 - 10
ACCURACY	A	[mm]	± [0.025+(0.02*L)] (L: stroke length in mt)
MAGNETIC TAPE PITCH	P	[mm]	2
MAX SPEED	S	[m/s]	It depends of resolution

SIN COS MAGNETIC ENCODER P2mm (FEEDBACK ORDER NR. 023)			
RATED VOLTAGE	Vn	[Vdc]	5 ± 2.5%
RATED CURRENT	In	[mA]	200
MAX OUTPUT FREQUENCY	F	[kHz]	5
WORKING TEMPERATURE	Tn	[°C]	0° ÷ + 50°
SIGNAL TYPE		[Vdc]	1 Vpp
ZERO PULSE			Not available
RESOLUTION	R	[μm]	Function of the interpolator
ACCURACY	A	[mm]	± [0.025+(0.02*L)] (L: stroke length in mt)
MAGNETIC TAPE PITCH	P	[mm]	2
MAX SPEED	S	[m/s]	It depends of interpolator

TTL MAGNETIC ENCODER P1mm (FEEDBACK ORDER NR. 031 - 032 - 033 - 034)			
RATED VOLTAGE	Vn	[Vdc]	5 ± 5%
RATED CURRENT	In	[mA]	25
MAX OUTPUT FREQUENCY	F	[kHz]	500
WORKING TEMPERATURE	Tn	[°C]	-10° ÷ + 70°
ELECTRONIC TYPE			LINE DRIVER AM 26 LS32
ZERO PULSE			STANDARD
RESOLUTION	R	[μm]	0.2 - 1 - 2 - 5
ACCURACY	A	[μm]	± 10 μm/m
MAGNETIC TAPE PITCH	P	[mm]	1
MAX SPEED	S	[m/s]	It depends of resolution

SIN COS MAGNETIC ENCODER P1mm (FEEDBACK ORDER NR. 030)			
RATED VOLTAGE	Vn	[Vdc]	5 ± 5%
RATED CURRENT	In	[mA]	50
MAX OUTPUT FREQUENCY	F	[kHz]	20
WORKING TEMPERATURE	Tn	[°C]	-10° ÷ + 70°
SIGNAL TYPE		[Vdc]	1 Vpp
ZERO PULSE			STANDARD
RESOLUTION	R	[μm]	Function of the interpolator
ACCURACY	A	[μm]	± 10 μm/m
MAGNETIC TAPE PITCH	P	[mm]	1
MAX SPEED	S	[m/s]	It depends of interpolator

HALL SENSOR			
RATED VOLTAGE	Vn	[Vdc]	5 ÷ 24
RATED CURRENT	In	[mA]	100
WORKING TEMPERATURE	Tn	[°C]	-20° ÷ +100°
N° OF COMMUTATION SIGNALS			3 Common Mode 5v

SERIES

SKA DDL 30.40 – 30.80

FORCE [N]

40/80

SINEWAVE FORM	SYMBOL	UNITS	TYPE OF WINDING XX = preferential winding			
			12	14	15	16
MOTOR SPEED	Vn drive 145 V (ac) 3phase	[m/s]	4.5	3	2	1.5
	Vn drive 220 V (ac) 3phase	[m/s]		4.5	3	2
	Vn drive 380 V (ac) 3phase	[m/s]			5	4

COMMON RATINGS

Voltage constant ± 5%	Ke	[Vrms/m/s]	24	36	55	72
Pole pitch	P	[mm]	12			
Temperature range	Tr	[°C]	0 ÷ 40°			

SKA DDL 30.40

Continuous force(0 m/s)	Fn0	[N]	40			
Peak force	Fmax	[N]	134.8			
Force constant ± 5%	Kf	[N/Arms]	40	60	91	
Rated current (0 m/s)	In0	[Arms]	1	0.67	0.44	
Peak current	I fmax	[Arms]	4	2.7	1.76	
Phase/phase res. ± 5% a 20°C	Rff	[Ohm]	8.9	20	46.75	
Phase/phase inductance	Lff	[mH]	24.7	55.75	129.7	
Electrical time constant	Te	[msec]	2.78			
Attraction force	Fm	[N]	260			
Power loss	Pd	[W]	18.1			
Thermal resistance	Rth	[°C/W]	4.42			
Motor constant	Km	[N/√W]	10.95			

SKA DDL 30.80

Continuous force(0 m/s)	Fn0	[N]	80			
Peak force	Fmax	[N]	269.6			
Force constant ± 5%	Kf	[N/Arms]	40	60	91	121
Rated current (0 m/s)	In0	[Arms]	2	1.33	3.5	0.66
Peak current	I fmax	[Arms]	8	5.33	2.97	2.64
Phase/phase res. ± 5% a 20°C	Rff	[Ohm]	4.27	9.6	22.41	108.5
Phase/phase inductance	Lff	[mH]	13.38	30.1	70.24	340
Electrical time constant	Te	[msec]	3.13			
Attraction force	Fm	[N]	520			
Power loss	Pd	[W]	34.6			
Thermal resistance	Rth	[°C/W]	2.31			
Motor constant	Km	[N/√W]	15.8			

Type of thermal cut-off

N C : normally closed

THERMAL PROTECTION	Rated voltage	Vn	[Vac]	250		
	Rated current	In	[A]	2.5		
	Operative temperature	Tn	[°C]	130 °C ± 5%		
	Resetting temperature	Tr	[°C]	100 °C ± 15°C		
	Operative time		[ms]	1		
	Insulation class			F		

Datasheet n°: SKADDL-2008-03-00

SERIES

SKA

DDL 30

FORCE [N]

40/80

MOTOR DIMENSIONS

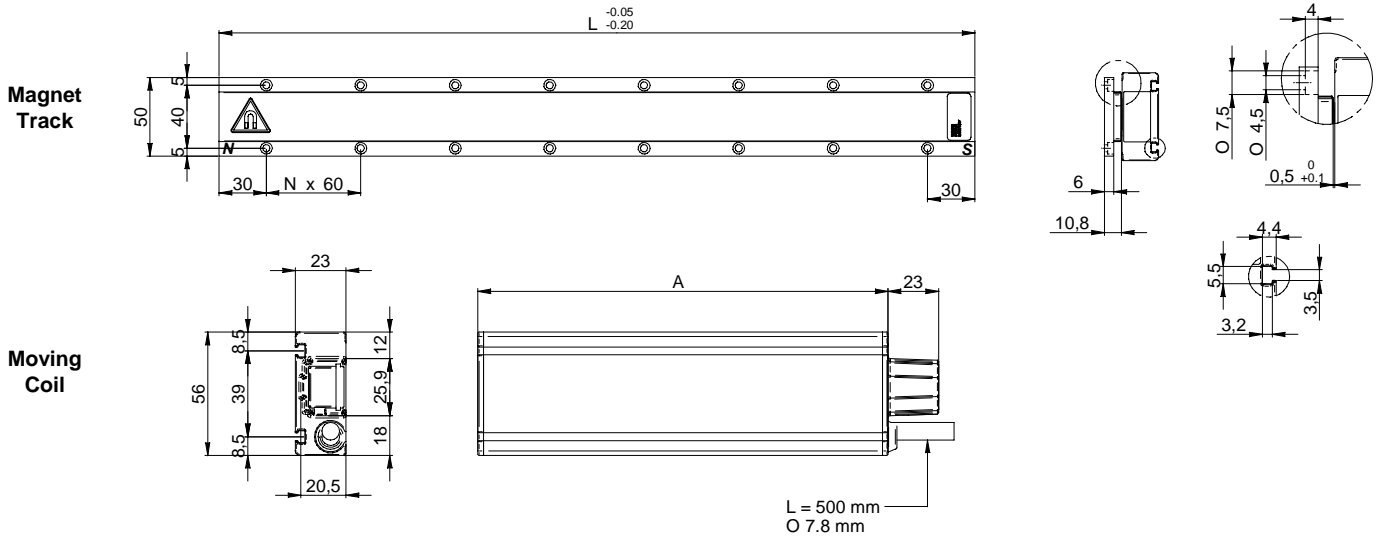

Magnet Track		Moving Coil	
Type	L (mm)	Type	A (mm)
30-120	120	30.40	102
30-240	240	30.80	186
30-480	480		

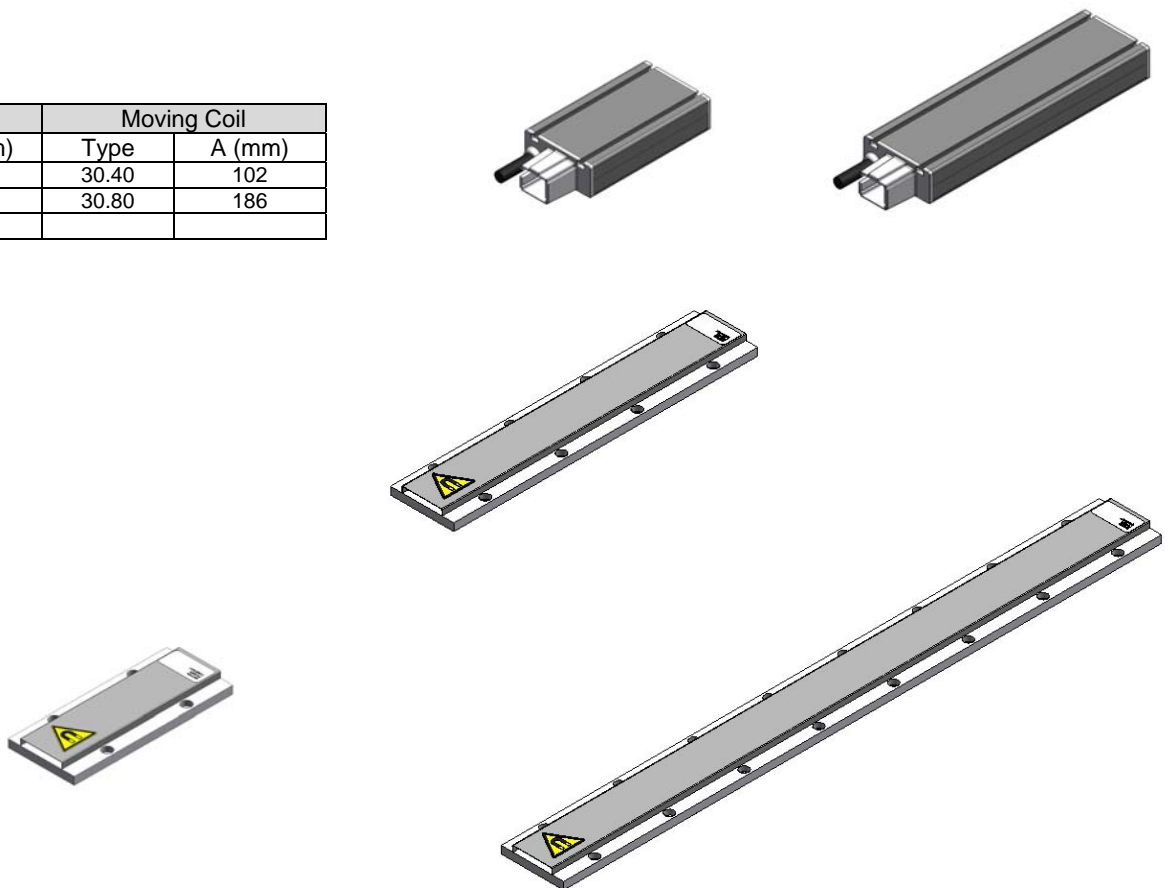

SERIES

SKA DDL 50.75 – 50.150

FORCE [N]

75/150

SINEWAVE FORM		SYMBOL	UNITS	TYPE OF WINDING XX = preferential winding				
				12	14	15	16	17
MOTOR SPEED	Vn drive 145 V (ac) 3phase		[m/s]	4.5	3	2	1.5	1.1
	Vn drive 220 V (ac) 3phase		[m/s]		4.5	3	2	1.5
	Vn drive 380 V (ac) 3phase		[m/s]			5	4	3

COMMON RATINGS								
Voltage constant ± 5%	Ke	[Vrms/m/s]	24	36	55	72	97	
Pole pitch	P	[mm]			12			
Temperature range	Tr	[°C]			0 ÷ 40°			

SKA DDL 50.75

MOTOR RATINGS	Continuous force(0 m/s)	Fn0	[N]			75		
	Peak force	Fmax	[N]			247		
	Force constant ± 5%	Kf	[N/Arms]	40	60	91	121	
	Rated current (0 m/s)	In0	[Arms]	1.88	1.25	0.82	0.62	
	Peak current	I fmax	[Arms]	7.5	5	3.28	2.48	
	Phase/phase res. ± 5% a 20°C	Rff	[Ohm]	3.71	8.34	19.5	33.4	
	Phase/phase inductance	Lff	[mH]	13	29.25	68.25	117	
	Electrical time constant	Te	[msec]				3.5	
	Attraction force	Fm	[N]			430		
	Power loss	Pd	[W]			26.55		
	Thermal resistance	Rth	[°C/W]			3.01		
	Motor constant	Km	[N/√W]			16.9		

SKA DDL 50.150

MOTOR RATINGS	Continuous force(0 m/s)	Fn0	[N]			150		
	Peak force	Fmax	[N]			495		
	Force constant ± 5%	Kf	[N/Arms]	40	60	91	121	161
	Rated current (0 m/s)	In0	[Arms]	3.76	2.5	1.64	1.24	0.93
	Peak current	I fmax	[Arms]	15	10	6.56	4.96	3.72
	Phase/phase res. ± 5% a 20°C	Rff	[Ohm]	1.78	4	9.35	16	29
	Phase/phase inductance	Lff	[mH]	7.1	15.98	37.27	63.9	115.94
	Electrical time constant	Te	[msec]			4		
	Attraction force	Fm	[N]			860		
	Power loss	Pd	[W]			51		
	Thermal resistance	Rth	[°C/W]			1.57		
	Motor constant	Km	[N/√W]			24.4		

THERMAL PROTECTION	Type of thermal cut-off		N C : normally closed		
	Rated voltage	Vn	[Vac]		250
	Rated current	In	[A]		2.5
	Operative temperature	Tn	[°C]		130 °C ± 5%
	Resetting temperature	Tr	[°C]		100 °C ± 15°C
	Operative time		[ms]		1
	Insulation class				F

Datasheet n°: SKADDL-2008-03-00

SERIES

SKA

DDL 50

FORCE [N]

75/150

MOTOR DIMENSIONS

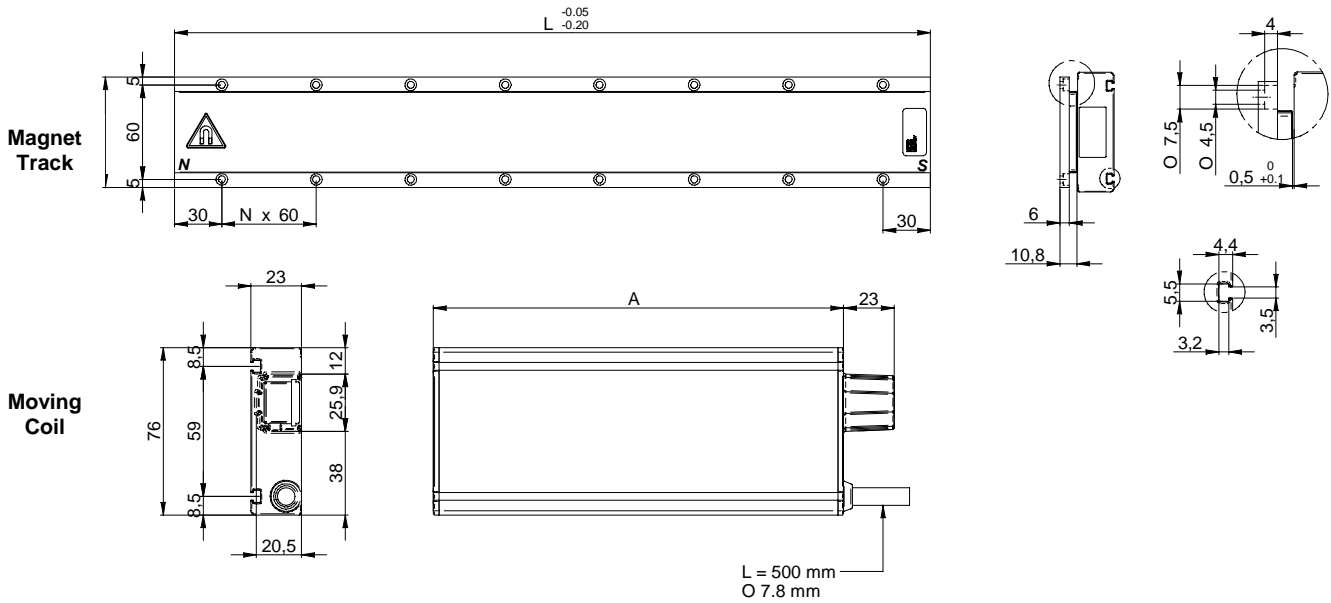

Magnet Track		Moving Coil	
Type	L (mm)	Type	A (mm)
50-120	120	50.75	102
50-240	240	50.150	186
50-480	480		

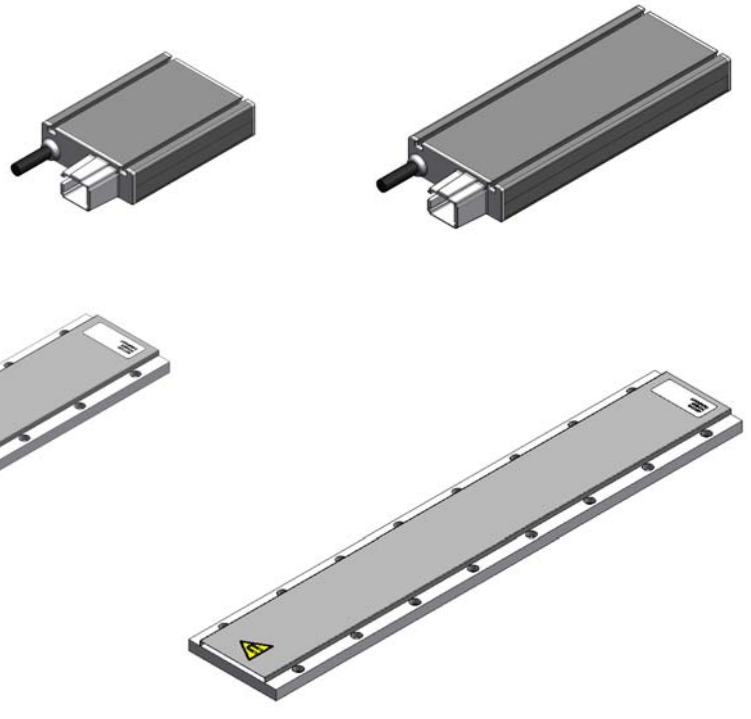

SERIES

SKA DDL 55.275 – 55.550

FORCE [N]

275/550

SINEWAVE FORM		SYMBOL	UNITS	TYPE OF WINDING XX = preferential winding						
				12	14	15	16	17	18	
MOTOR SPEED	Vn drive 145 V (ac) 3phase		[m/s]	4.5	3	2	1.5	1.1		
	Vn drive 220 V (ac) 3phase		[m/s]		4.5	3	2	1.5	1	
	Vn drive 380 V (ac) 3phase		[m/s]			5	4	3	2	
COMMON RATINGS										
	Voltage constant ± 5%	Ke	[Vrms/m/s]	24	36	55	72	97	145	
	Pole pitch	P	[mm]				24			
	Temperature range	Tr	[°C]				0 ÷ 40°			
SKA DDL 55.275										
MOTOR RATINGS	Continuous force(0 m/s)	Fn0	[N]				275			
	Peak force	Fmax	[N]				825			
	Force constant ± 5%	Kf	[N/Arms]	40	60	91	121	161	241	
	Rated current (0 m/s)	In0	[Arms]	6.9	4.6	3.0	2.28	1.71	1.14	
	Peak current	I fmax	[Arms]	27.6	18.38	12.0	9.13	6.84	4.56	
	Phase/phase res. ± 5% a 20°C	Rff	[Ohm]	0.933	2.1	4.9	8.4	12.9	34.06	
	Phase/phase inductance	Lff	[mH]	14.8	33.2	77.5	132.8	235.4	538.6	
	Electrical time constant	Te	[msec]				15.8			
	Attraction force	Fm	[N]				1202			
	Power loss	Pd	[W]				86.8			
	Thermal resistance	Rth	[°C/W]				0.921			
	Motor constant	Km	[N/√W]				33.8			
	SKA DDL 55. 550									
	Continuous force(0 m/s)	Fn0	[N]				550			
	Peak force	Fmax	[N]				1650			
	Force constant ± 5%	Kf	[N/Arms]	37	56	86	113	151	226	
	Rated current (0 m/s)	In0	[Arms]	14.72	9.8	6.41	4.87	3.65	2.44	
	Peak current	I fmax	[Arms]	58.86	39.2	25.65	19.47	14.59	9.73	
	Phase/phase res. ± 5% a 20°C	Rff	[Ohm]	0.45	0.98	2.33	3.98	7.21	16.21	
	Phase/phase inductance	Lff	[mH]	8.1	18.2	42.5	72.85	131.4	295.5	
	Electrical time constant	Te	[msec]				18.22			
	Attraction force	Fm	[N]				2405			
	Power loss	Pd	[W]				191.5			
	Thermal resistance	Rth	[°C/W]				0.418			
	Motor constant	Km	[N/√W]				45.6			
THERMAL PROTECTION	Type of thermal cut-off			N C : normally closed						
	Rated voltage	Vn	[Vac]	250						
	Rated current	In	[A]	2.5						
	Operative temperature	Tn	[°C]	130 °C ± 5%						
	Resetting temperature	Tr	[°C]	100 °C ± 15°C						
	Operative time		[ms]	1						
	Insulation class			F						

Datasheet n°: SKADDL-2008-03-00

SERIES

SKA

DDL 55

FORCE [N]

275/550

MOTOR DIMENSIONS

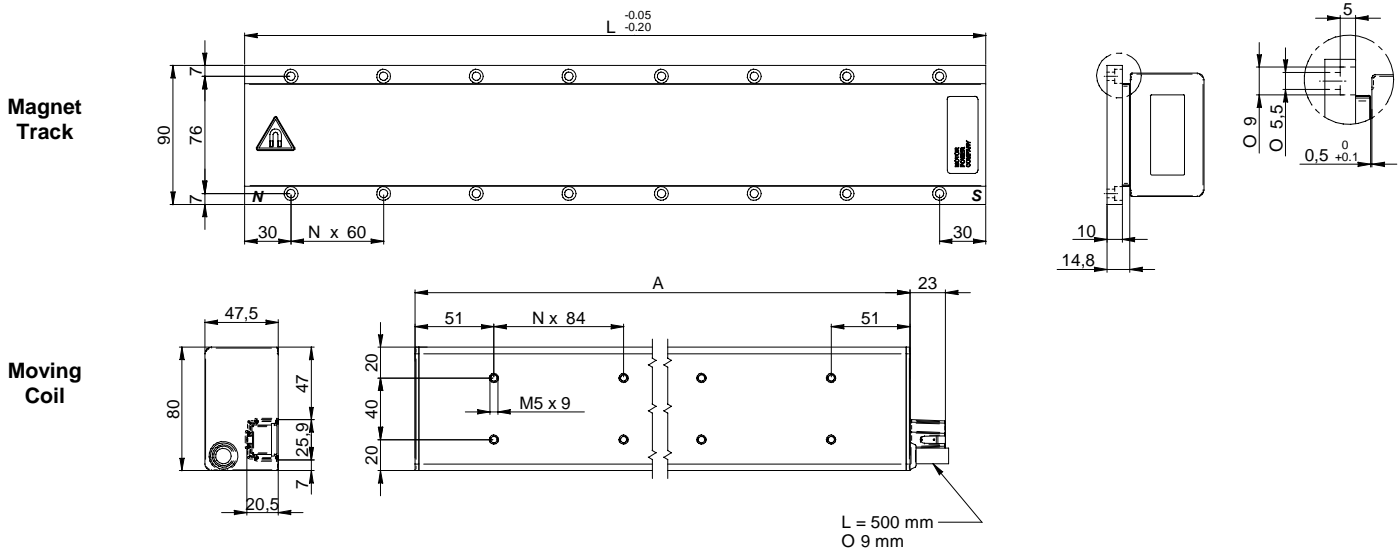

Magnet Track		Moving Coil	
Type	L (mm)	Type	A (mm)
55-120	120	55.275	186
55-240	240	55.550	354
55-480	480		

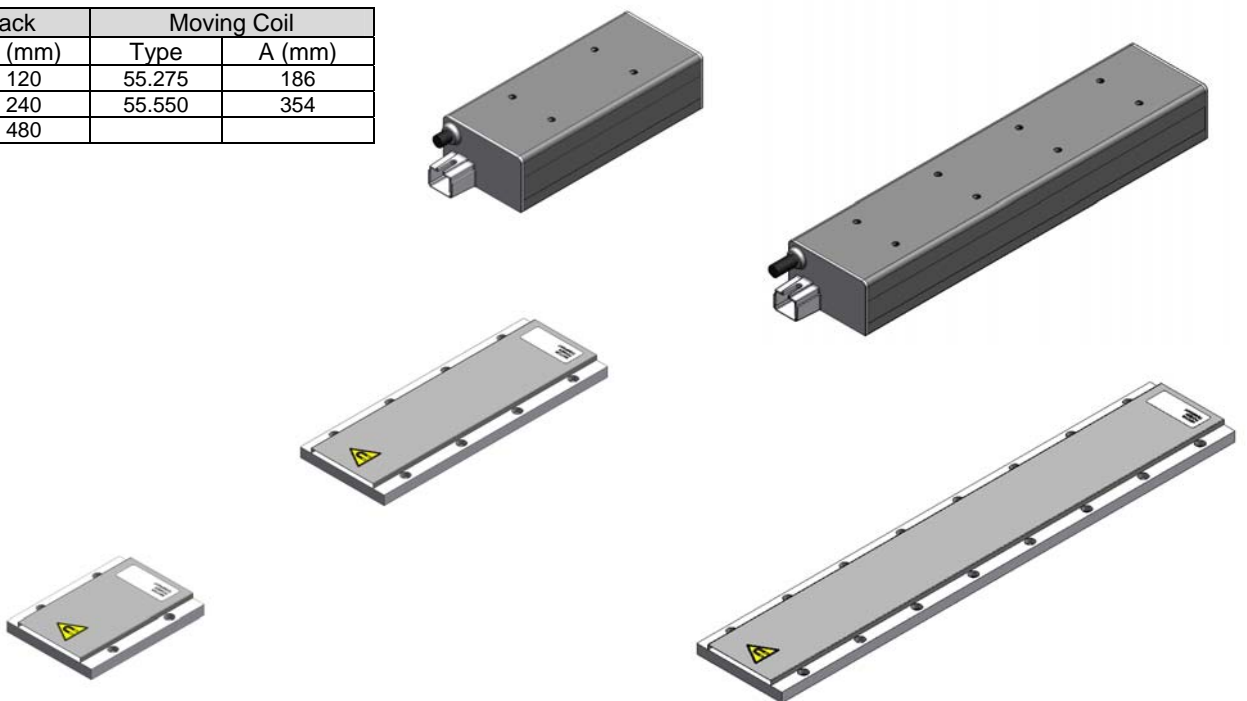

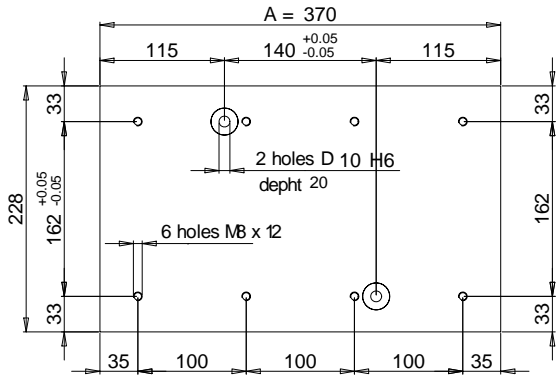

SKA DDL 55.550

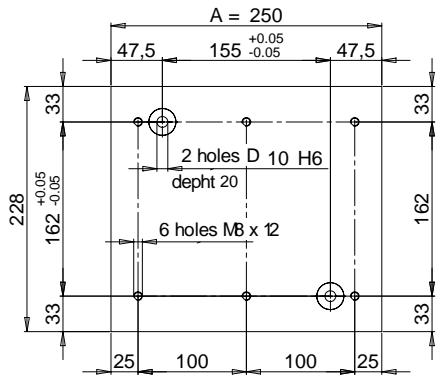

SKA DDL 55.275

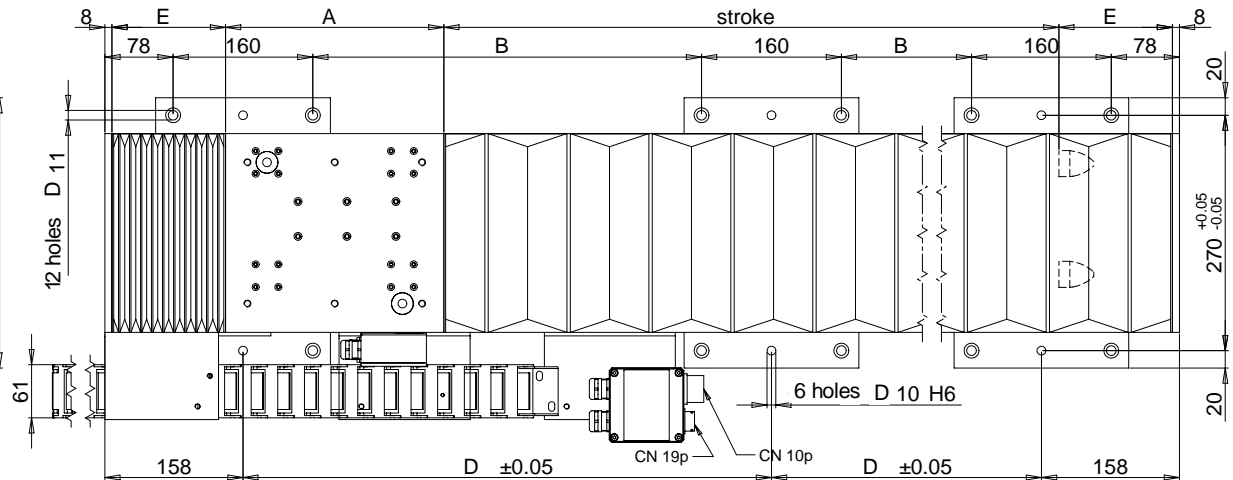
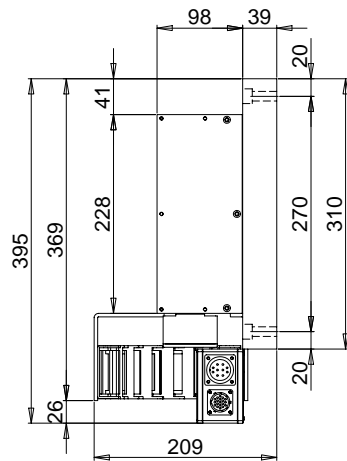
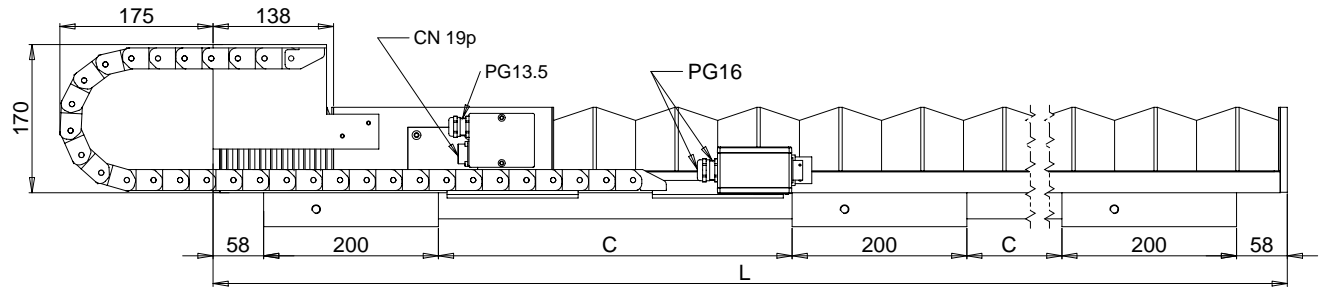

Series

SKA DDL 55.275 – 55.550 *Linear Stage version*

Datasheet n°: SKADDL-2008-03-00

STROKE [mm]	500		700		1000		1200		1500		1800		2000		2500		3000	
TYPE SKA DDL	55.275	55.550	55.275	55.550	55.275	55.550	55.275	55.550	55.275	55.550	55.275	55.550	55.275	55.550	55.275	55.550	55.275	55.550
L	996	1116	1196	1316	1526	1646	1786	1906	2146	2266	2526	2646	2766	2886	3366	3486	3986	4106
A	250	370	250	370	250	370	250	370	250	370	250	370	250	370	250	370	250	370
B	180	240	280	340	445	505	575	635	755	815	945	1005	1065	1125	1365	1425	1675	1735
C	140	200	240	300	405	465	535	595	715	775	905	965	1025	1085	1325	1385	1635	1695
D	340	400	440	500	605	665	735	795	915	975	1105	1165	1225	1285	1525	1585	1835	1895
E	115	115	115	115	130	130	160	160	190	190	230	230	250	250	300	300	360	360

SERIES

SKA DDL 75.660 – 75.990

FORCE [N]

660/990

SINEWAVE FORM		SYMBOL	UNITS	TYPE OF WINDING XX = preferential winding						
				12	14	15	16	17	18	
MOTR SPEED	Vn drive 145 V (ac) 3phase		[m/s]	4.5	3	2	1.5	1.1		
	Vn drive 220 V (ac) 3phase		[m/s]		4.5	3	2	1.5	1	
	Vn drive 380 V (ac) 3phase		[m/s]			5	4	3	2	
COMMON RATINGS										
	Voltage constant ± 5%	Ke	[Vrms/m/s]	24	36	55	72	97	145	
	Pole pitch	P	[mm]				24			
	Temperature range	Tr	[°C]				0 ÷ 40°			
SKA DDL 75.660										
MOTOR RATINGS	Continuous force(0 m/s)	Fn0	[N]				660			
	Peak force	Fmax	[N]				1980			
	Force constant ± 5%	Kf	[N/Arms]	37	56	86	113	151	226	
	Rated current (0 m/s)	In0	[Arms]	17.66	11.76	7.7	5.85	4.38	2.92	
	Peak current	I fmax	[Arms]	70.6	47	30.78	23.36	17.5	11.7	
	Phase/phase res. ± 5% a 20°C	Rff	[Ohm]	0.37	0.83	1.93	3.31	6.04	13.6	
	Phase/phase inductance	Lff	[mH]	5.7	12.8	30.2	51.5	93.8	210.9	
	Electrical time constant	Te	[msec]				15.4			
	Attraction force	Fm	[N]				3143			
	Power loss	Pd	[W]				229			
	Thermal resistance	Rth	[°C/W]				0.349			
	Motor constant	Km	[N/√W]				50			
	SKA DDL 75.990									
	Continuous force(0 m/s)	Fn0	[N]				990			
	Peak force	Fmax	[N]				2970			
	Force constant ± 5%	Kf	[N/Arms]		56	86	113	151	226	
	Rated current (0 m/s)	In0	[Arms]		17.65	11.54	8.76	6.57	4.38	
	Peak current	I fmax	[Arms]		70.56	46.17	35	26.25	17.52	
	Phase/phase res. ± 5% a 20°C	Rff	[Ohm]		0.57	1.31	2.25	4.05	9.12	
	Phase/phase inductance	Lff	[mH]		8.6	19.9	34.1	61.5	138.4	
	Electrical time constant	Te	[msec]				18.22			
	Attraction force	Fm	[N]				4663			
	Power loss	Pd	[W]				352.8			
	Thermal resistance	Rth	[°C/W]				0.227			
	Motor constant	Km	[N/√W]				60.4			
THERMAL PROTECTION	Type of thermal cut-off						N C : normally closed			
	Rated voltage	Vn	[Vac]				250			
	Rated current	In	[A]				2.5			
	Operative temperature	Tn	[°C]				130 °C ± 5%			
	Resetting temperature	Tr	[°C]				100 °C ± 15°C			
	Operative time		[ms]				1			
	Insulation class						F			

Datasheet n°: SKADDL – 2008-03-00

SERIES

SKA

DDL 75

FORCE [N]

660/990

MOTOR DIMENSIONS

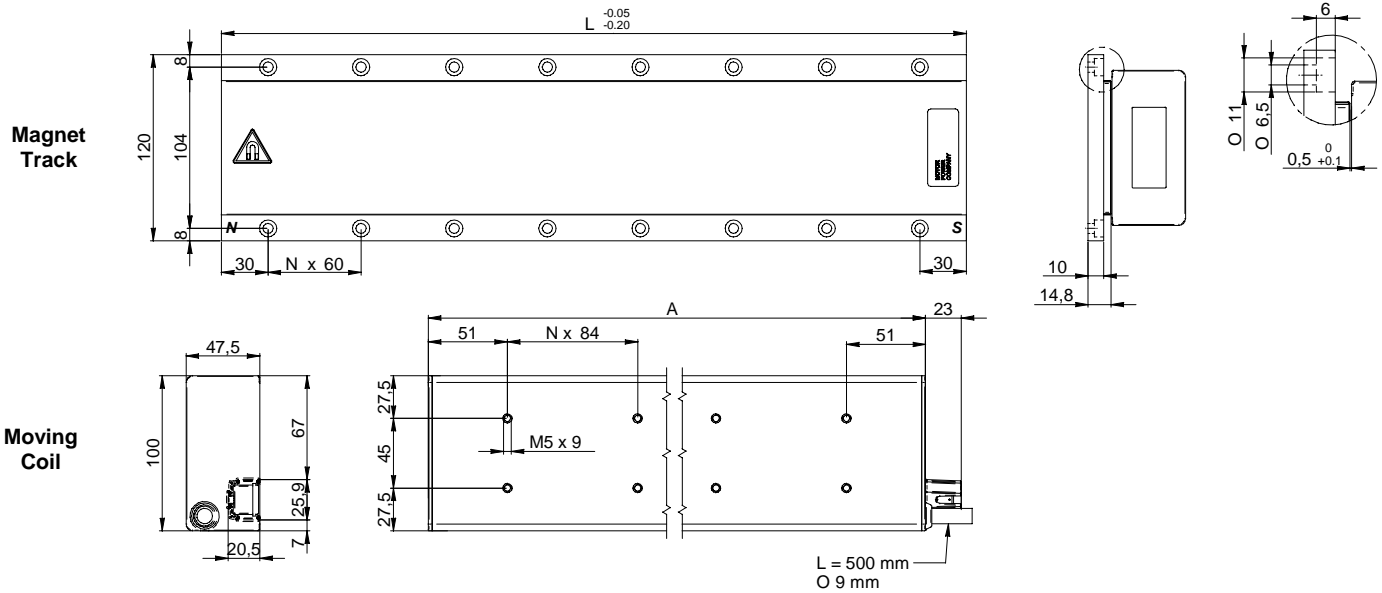

Magnet Track		Moving Coil	
Type	L (mm)	Type	A (mm)
75-120	120	75.660	354
75-240	240	75.990	522
75-480	480		

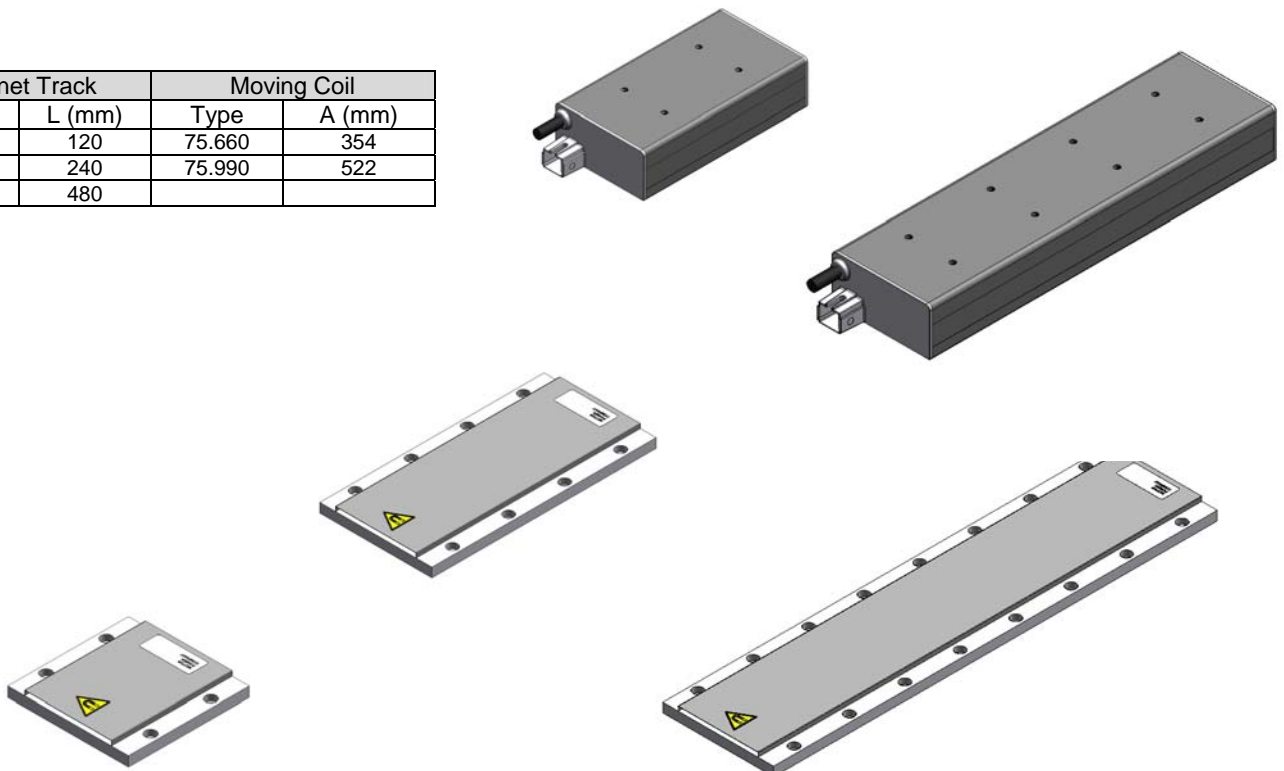

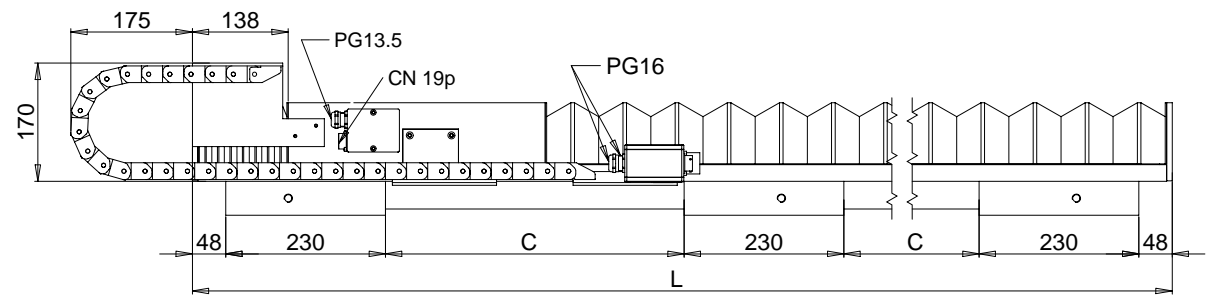
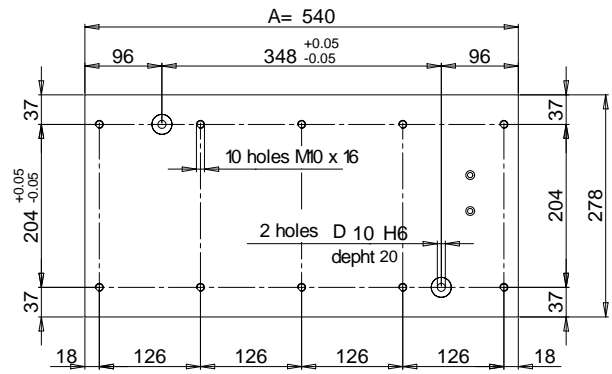

SKA DDL 75.990

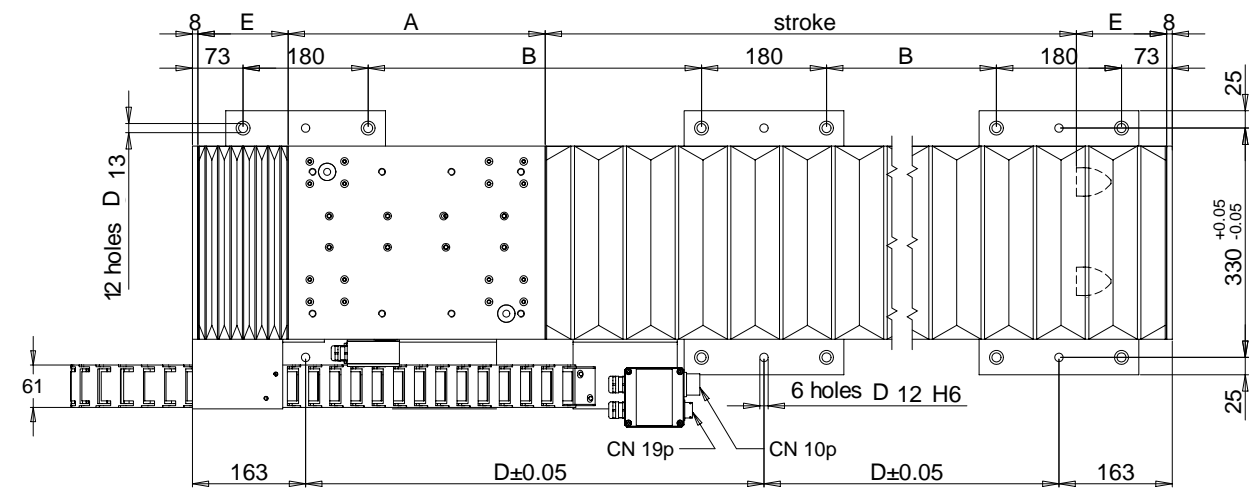
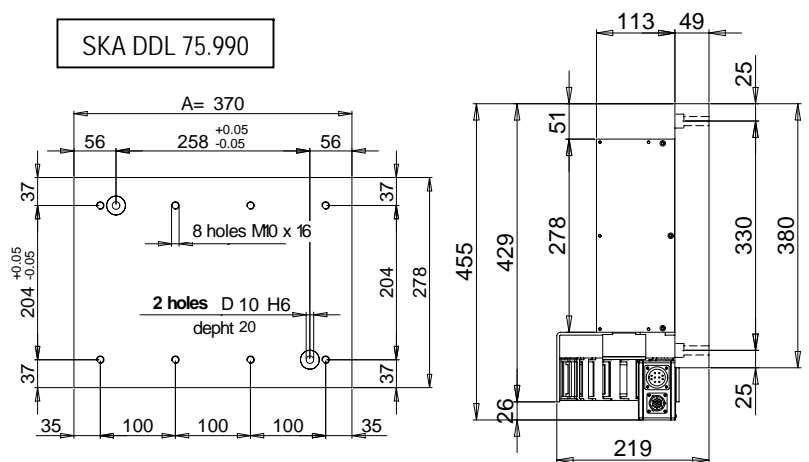

SKA DDL 75.660



Series
SKA DDL 75.660 – 75.990 *Linear Stage version*

Datasheet n°: SKADDL-2008-03-00

STROKE [mm]	500		700		1000		1200		1500		1800		2000		2500		3000	
TYPE SKA DDL	75.660	75.990	75.660	75.990	75.660	75.990	75.660	75.990	75.660	75.990	75.660	75.990	75.660	75.990	75.660	75.990	75.660	75.990
L	1146	1316	1346	1516	1646	1816	1906	2076	2266	2436	2646	2816	2886	3056	3486	3656	4106	4276
A	370	540	370	540	370	540	370	540	370	540	370	540	370	540	370	540	370	540
B	255	340	355	440	505	590	635	720	815	900	1005	1090	1125	1210	1425	1510	1735	1820
C	215	300	315	400	465	550	595	680	775	860	965	1050	1085	1170	1385	1470	1695	1780
D	415	500	515	600	665	750	795	880	975	1060	1165	1250	1285	1370	1585	1670	1895	1980
E	130	130	130	130	130	130	160	160	190	190	230	230	250	250	300	300	360	360

SERIES

SKA DDL 100.1200 – 100.1600

FORCE [N]
1200/1600

SINEWAVE FORM		SYMBOL	UNITS	TYPE OF WINDING XX = preferential winding			
				15	16	17	18
MOTOR SPEED	Vn drive 145 V (ac) 3phase		[m/s]	2	1.5	1.1	
	Vn drive 220 V (ac) 3phase		[m/s]	3	2	1.5	1
	Vn drive 380 V (ac) 3phase		[m/s]	5	4	3	2
COMMON RATINGS							
	Voltage constant ± 5%	Ke	[Vrms/m/s]	55	72	97	145
	Pole pitch	P	[mm]			24	
	Temperature range	Tr	[°C]			0 ÷ 40°	
SKA DDL 100.1200							
MOTOR RATINGS	Continuous force(0 m/s)	Fn0	[N]			1200	
	Peak force	Fmax	[N]			3600	
	Force constant ± 5%	Kf	[N/Arms]	86	113	151	226
	Rated current (0 m/s)	In0	[Arms]	14	10.6	7.96	5.3
	Peak current	I fmax	[Arms]	56	42.5	31.8	21.3
	Phase/phase res. ± 5% a 20°C	Rff	[Ohm]	0.83	1.43	2.56	5.75
	Phase/phase inductance	Lff	[mH]	15.9	27.3	49.2	110.5
	Electrical time constant	Te	[msec]			19	
	Attraction force	Fm	[N]			5831	
	Power loss	Pd	[W]			352	
	Thermal resistance	Rth	[°C/W]			0.227	
	Motor constant	Km	[N/√W]			73.2	
	SKA DDL 100.1600						
	Continuous force(0 m/s)	Fn0	[N]			1600	
	Peak force	Fmax	[N]			4800	
	Force constant ± 5%	Kf	[N/Arms]	84	110	147	221
	Rated current (0 m/s)	In0	[Arms]	19.1	14.5	10.9	7.24
	Peak current	I fmax	[Arms]	74.4	56.5	42.3	28.3
	Phase/phase res. ± 5% a 20°C	Rff	[Ohm]	0.645	1.1	1.92	4.3
	Phase/phase inductance	Lff	[mH]	11.9	21.3	36.9	82.9
	Electrical time constant	Te	[msec]			19.27	
	Attraction force	Fm	[N]			7774	
	Power loss	Pd	[W]			470	
	Thermal resistance	Rth	[°C/W]			0.17	
	Motor constant	Km	[N/√W]			84.6	
THERMAL PROTECTION	Type of thermal cut-off					N C : normally closed	
	Rated voltage	Vn	[Vac]			250	
	Rated current	In	[A]			2.5	
	Operative temperature	Tn	[°C]			130 °C ± 5%	
	Resetting temperature	Tr	[°C]			100 °C ± 15°C	
	Operative time		[ms]			1	
	Insulation class					F	

Datasheet n°: SKADDL – 2008-03-00

SERIES

SKA

DDL 100

FORCE [N]

1200/1600

MOTOR DIMENSIONS

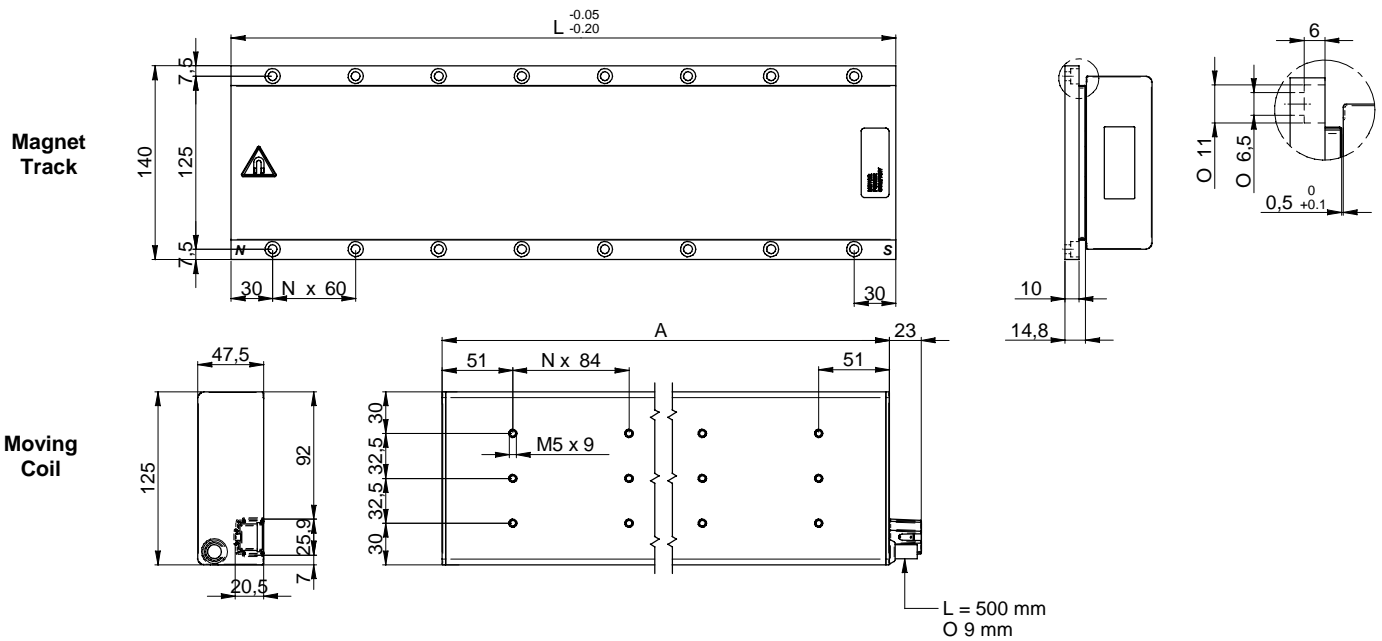

Magnet Track		Moving Coil	
Type	L (mm)	Type	A (mm)
100-120	120	100.1200	522
100-240	240	100.1600	690
100-480	480		

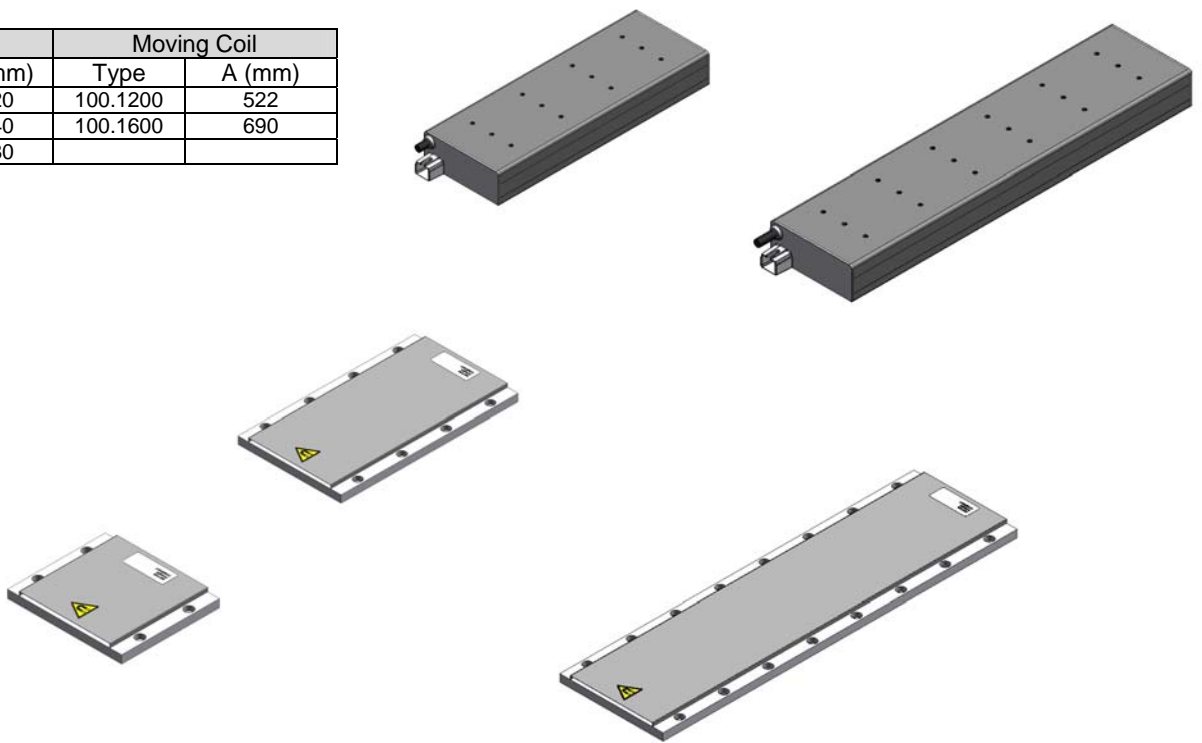

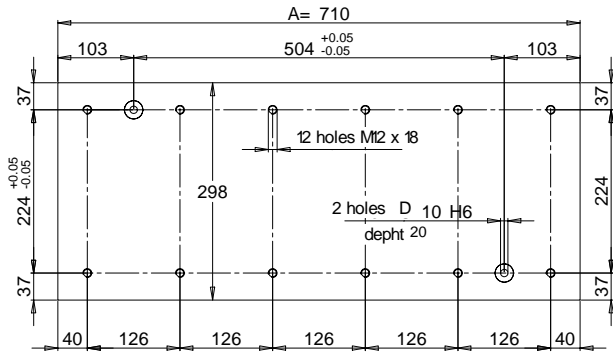

SKA DDL100.1600

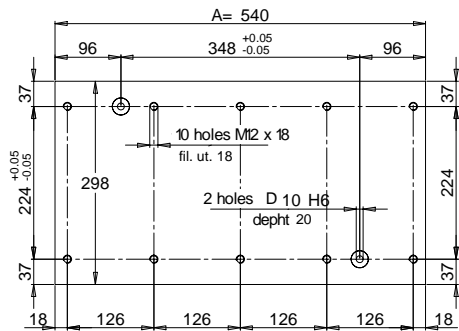

SKA DDL 100.1200

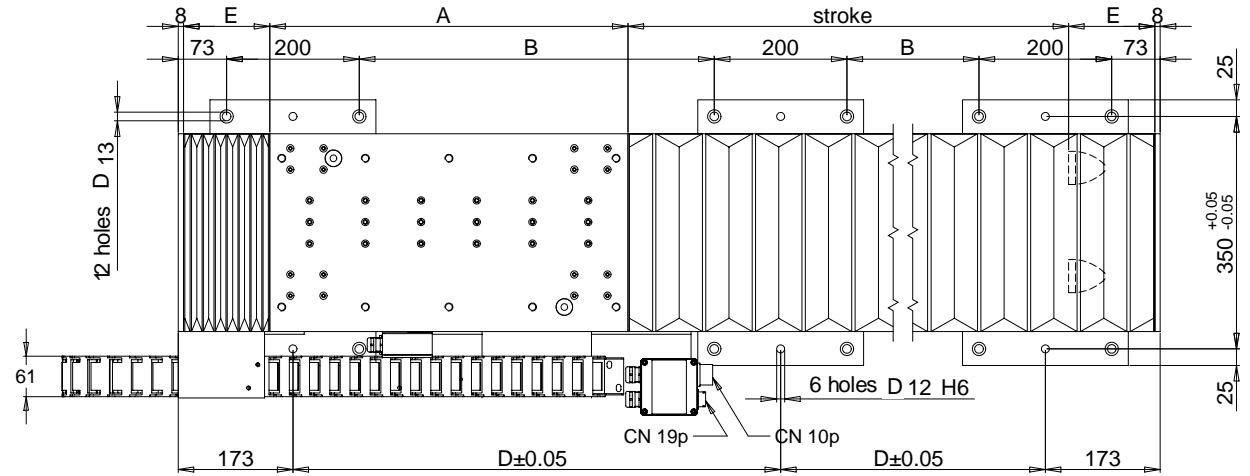
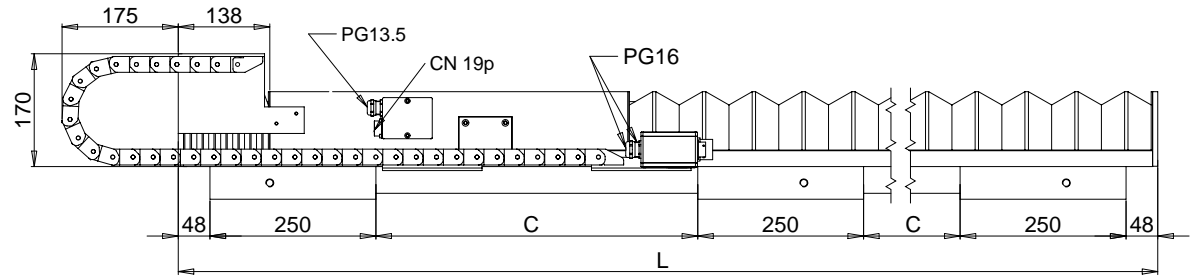
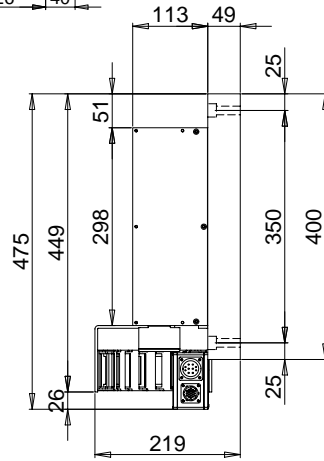

MOTOR POWER COMPANY Series
SKA DDL 100.1200 – 100.1600 *Linear Stage version*

Datasheet n°: SKADDL-2008-03-00

STROKE [mm]	500		700		1000		1200		1500		1800		2000		2500		3000	
TYPE SKA DDL	100.1200	100.1600	100.1200	100.1600	100.1200	100.1600	100.1200	100.1600	100.1200	100.1600	100.1200	100.1600	100.1200	100.1600	100.1200	100.1600	100.1200	100.1600
L	1316	1486	1516	1686	1816	1986	2076	2246	2436	2606	2816	2986	3056	3226	3656	3826	4276	4446
A	540	710	540	710	540	710	540	710	540	710	540	710	540	710	540	710	540	710
B	285	370	385	470	535	620	665	750	845	930	1035	1120	1155	1240	1455	1540	1765	1850
C	235	320	335	420	485	570	615	700	795	880	985	1070	1105	1190	1405	1490	1715	1800
D	485	570	585	670	735	820	865	950	1045	1130	1235	1320	1305	1440	1655	1740	1965	2050
E	130	130	130	130	130	130	160	160	190	190	230	230	250	250	300	300	360	360

SERIES

SKA DDL 125.2000

FORCE [N]

2000

SINEWAVE FORM		SYMBOL	UNITS	TYPE OF WINDING XX = preferential winding			
				16	17	18	19
MOTR SPEED	Vn drive 145 V (ac) 3phase		[m/s]	1.5	1.1		
	Vn drive 220 V (ac) 3phase		[m/s]	2	1.5	1	
	Vn drive 380 V (ac) 3phase		[m/s]	4	3	2	1.2
COMMON RATINGS							
	Voltage constant ± 5%	Ke	[Vrms/m/s]	72	97	145	242
	Pole pitch	P	[mm]			24	
	Temperature range	Tr	[°C]			0 ÷ 40°	
SKA DDL 125.2000							
MOTOR RATINGS	Continuous force(0 m/s)	Fn0	[N]			2000	
	Peak force	Fmax	[N]			6000	
	Force constant ± 5%	Kf	[N/Arms]	113	151	226	369
	Rated current (0 m/s)	In0	[Arms]	18.1	13.57	9.1	5.42
	Peak current	I fmax	[Arms]	70.6	52.9	35.3	21.13
	Phase/phase res. ± 5% a 20°C	Rff	[Ohm]	0.84	1.52	3.42	9.5
	Phase/phase inductance	Lff	[mH]	15.9	28.7	64.8	189.7
	Electrical time constant	Te	[msec]			18.9	
	Attraction force	Fm	[N]			9826	
	Power loss	Pd	[W]			600	
	Thermal resistance	Rth	[°C/W]			0.133	
	Motor constant	Km	[N/√W]			93.6	
	SKA DDL 125.2000						
	Continuous force(0 m/s)	Fn0	[N]			2000	
	Peak force	Fmax	[N]			6000	
	Force constant ± 5%	Kf	[N/Arms]	113	151	226	369
	Rated current (0 m/s)	In0	[Arms]	18.1	13.57	9.1	5.42
	Peak current	I fmax	[Arms]	70.6	52.9	35.3	21.13
	Phase/phase res. ± 5% a 20°C	Rff	[Ohm]	0.84	1.52	3.42	9.5
	Phase/phase inductance	Lff	[mH]	15.9	28.7	64.8	189.7
	Electrical time constant	Te	[msec]			18.9	
	Attraction force	Fm	[N]			9826	
	Power loss	Pd	[W]			600	
	Thermal resistance	Rth	[°C/W]			0.133	
	Motor constant	Km	[N/√W]			93.6	
THERMAL PROTECTION	Type of thermal cut-off			N C : normally closed			
	Rated voltage	Vn	[Vac]	250			
	Rated current	In	[A]	2.5			
	Operative temperature	Tn	[°C]	130 °C ± 5%			
	Resetting temperature	Tr	[°C]	100 °C ± 15°C			
	Operative time		[ms]	1			
	Insulation class			F			

Datasheet n°: SKADDL – 2008-03-00

SERIES

SKA

DDL 125

FORCE [N]

2000

MOTOR DIMENSIONS

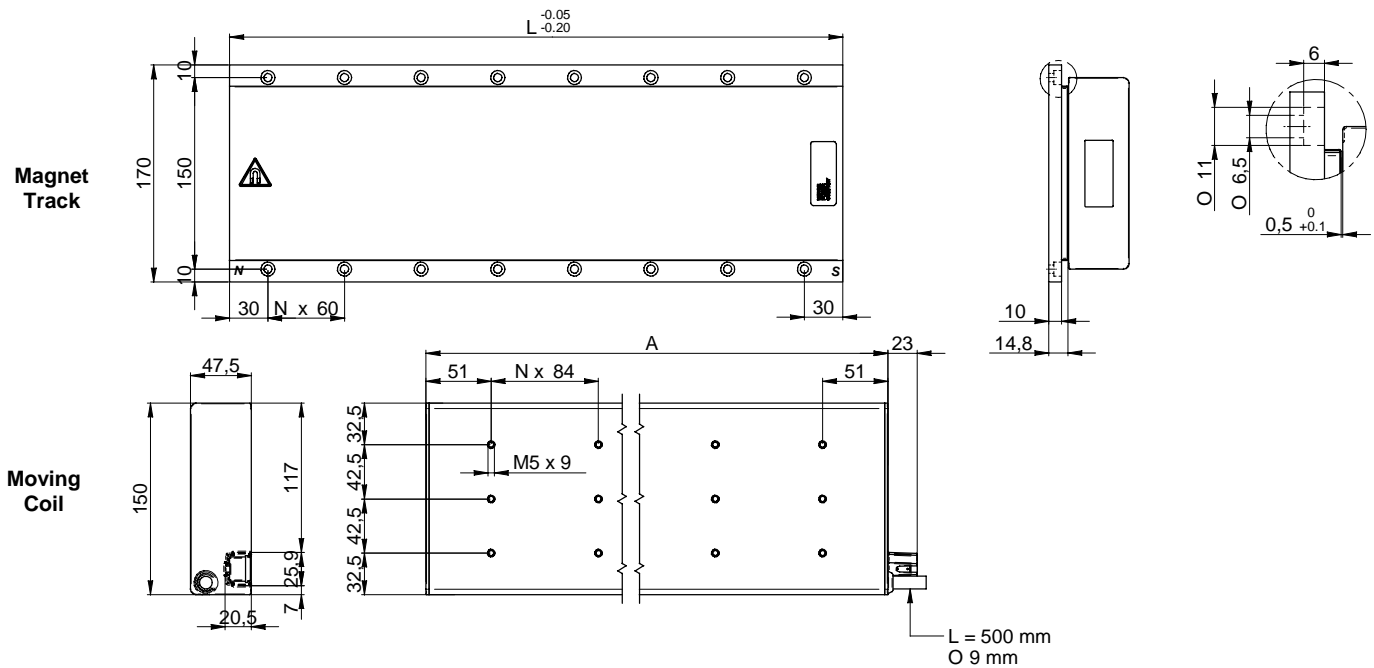

Magnet Track		Moving Coil	
Type	L (mm)	Type	A (mm)
125-120	120	125.2000	690
125-240	240		
125-480	480		

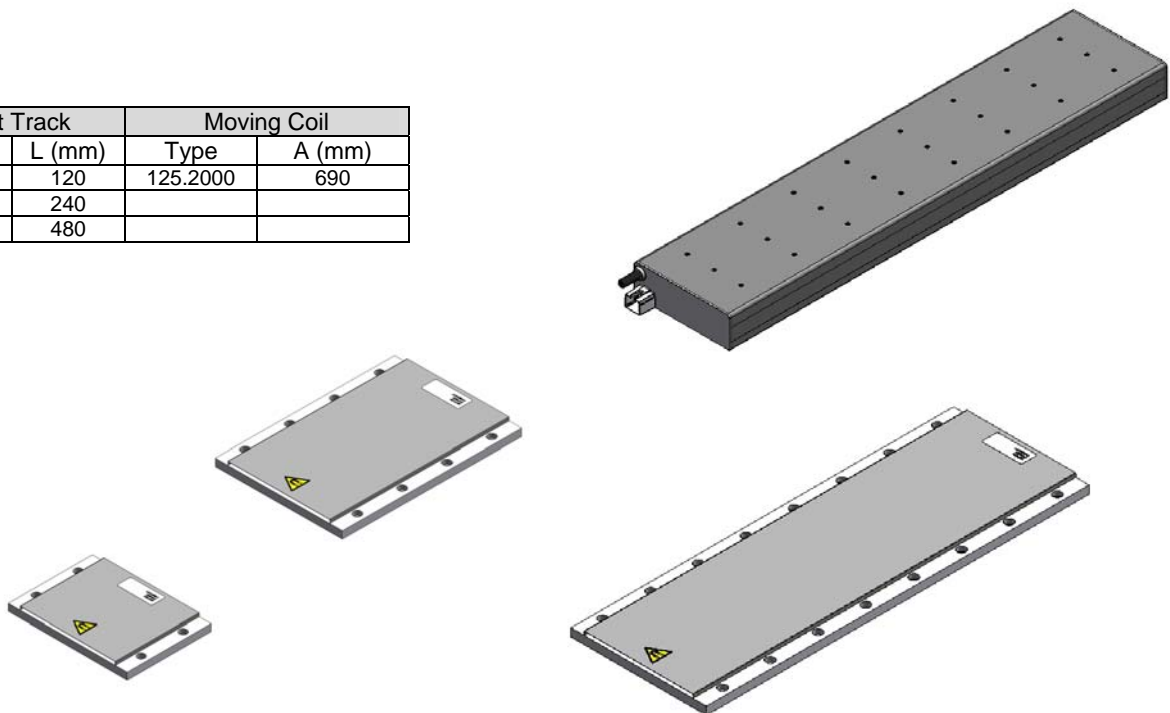

Datasheet n°: SKADDL-2008-03-00

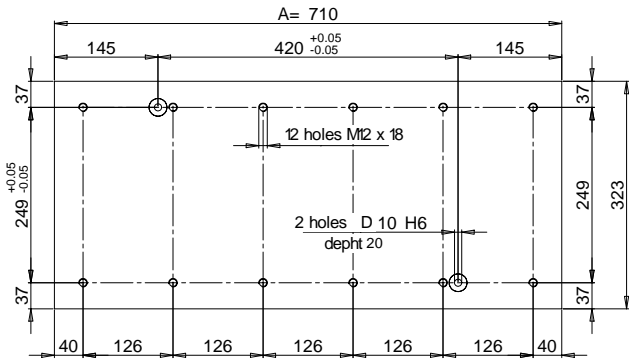

SKA DDL 125.2000

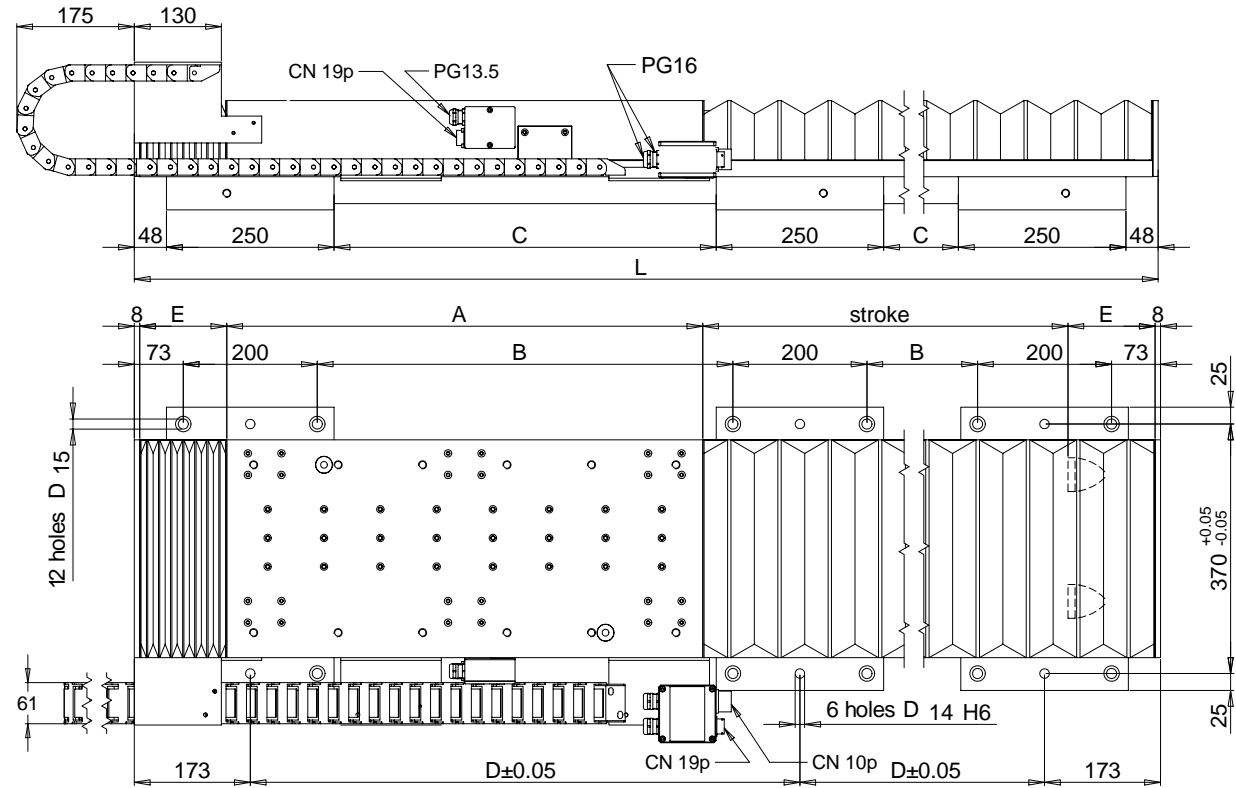
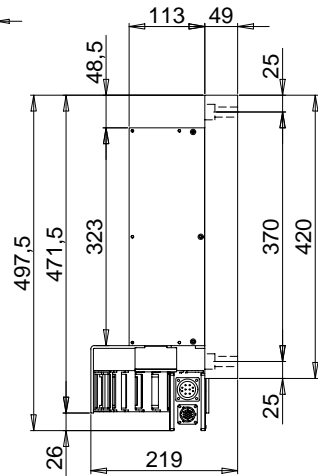

Series
SKA DDL 125.2000 *Linear Stage version*

Datasheet n°: SKADDL-2008-03-00

STROKE [mm]	500	700	1000	1200	1500	1800	2000	2500	3000
TYPE SKA DDL	125.2000	125.2000	125.2000	125.2000	125.2000	125.2000	125.2000	125.2000	125.2000
L	1486	1686	1986	2246	2606	2986	3226	3826	4446
A	710	710	710	710	710	710	710	710	710
B	370	470	620	750	930	1120	1240	1540	1850
C	320	420	570	700	880	1070	1190	1490	1800
D	570	670	820	950	1130	1320	1440	1740	2050
E	130	130	130	160	190	230	250	300	360

SERIES

SKA DDL 150.2400

FORCE [N]
2400

SINEWAVE FORM		SYMBOL	UNITS	TYPE OF WINDING XX = preferential winding				
				17	18	19		
MOTOR SPEED	Vn drive 145 V (ac) 3phase		[m/s]	1.1				
	Vn drive 220 V (ac) 3phase		[m/s]	1.5	1			
	Vn drive 380 V (ac) 3phase		[m/s]	3	2	1.2		
COMMON RATINGS								
	Voltage constant ± 5%	Ke	[Vrms/m/s]	97	145	242		
	Pole pitch	P	[mm]		24			
	Temperature range	Tr	[°C]		0 ÷ 40°			
SKA DDL 150.2400								
MOTOR RATINGS	Continuous force(0 m/s)	Fn0	[N]		2400			
	Peak force	Fmax	[N]		7200			
	Force constant ± 5%	Kf	[N/Arms]	151	226	369		
	Rated current (0 m/s)	In0	[Arms]	16.27	10.86	6.5		
	Peak current	I fmax	[Arms]	52.9	35.3	25.4		
	Phase/phase res. ± 5% a 20°C	Rff	[Ohm]	1.22	2.74	7.63		
	Phase/phase inductance	Lff	[mH]	25.2	56.6	157.5		
	Electrical time constant	Te	[msec]		20.6			
	Attraction force	Fm	[N]		11790			
	Power loss	Pd	[W]		693			
	Thermal resistance	Rth	[°C/W]		0.115			
	Motor constant	Km	[N/√W]		104.5			
	SKA DDL 150.2400							
	Continuous force(0 m/s)	Fn0	[N]					
	Peak force	Fmax	[N]					
	Force constant ± 5%	Kf	[N/Arms]					
	Rated current (0 m/s)	In0	[Arms]					
	Peak current	I fmax	[Arms]					
	Phase/phase res. ± 5% a 20°C	Rff	[Ohm]					
	Phase/phase inductance	Lff	[mH]					
	Electrical time constant	Te	[msec]					
	Attraction force	Fm	[N]					
	Power loss	Pd	[W]					
	Thermal resistance	Rth	[°C/W]					
	Motor constant	Km	[N/√W]					
THERMAL PROTECTION	Type of thermal cut-off			N C : normally closed				
	Rated voltage	Vn	[Vac]	250				
	Rated current	In	[A]	2.5				
	Operative temperature	Tn	[°C]	130 °C ± 5%				
	Resetting temperature	Tr	[°C]	100 °C ± 15°C				
	Operative time		[ms]	1				
	Insulation class			F				

Datasheet n°: SKADDL – 2008-03-00

SERIES

SKA

DDL 150

FORCE [N]

2400

MOTOR DIMENSIONS

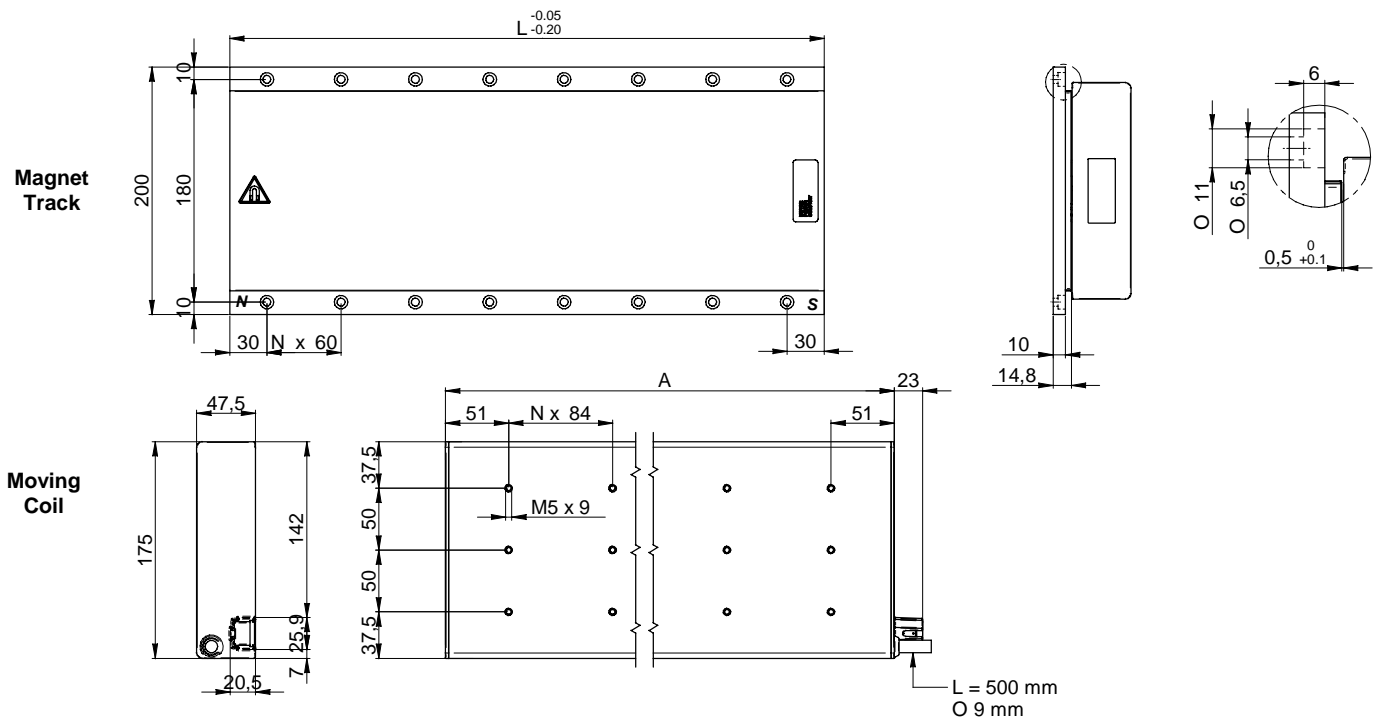

Magnet Track		Moving Coil	
Type	L (mm)	Type	A (mm)
150-120	120	150.2400	690
150-240	240		
150-480	480		

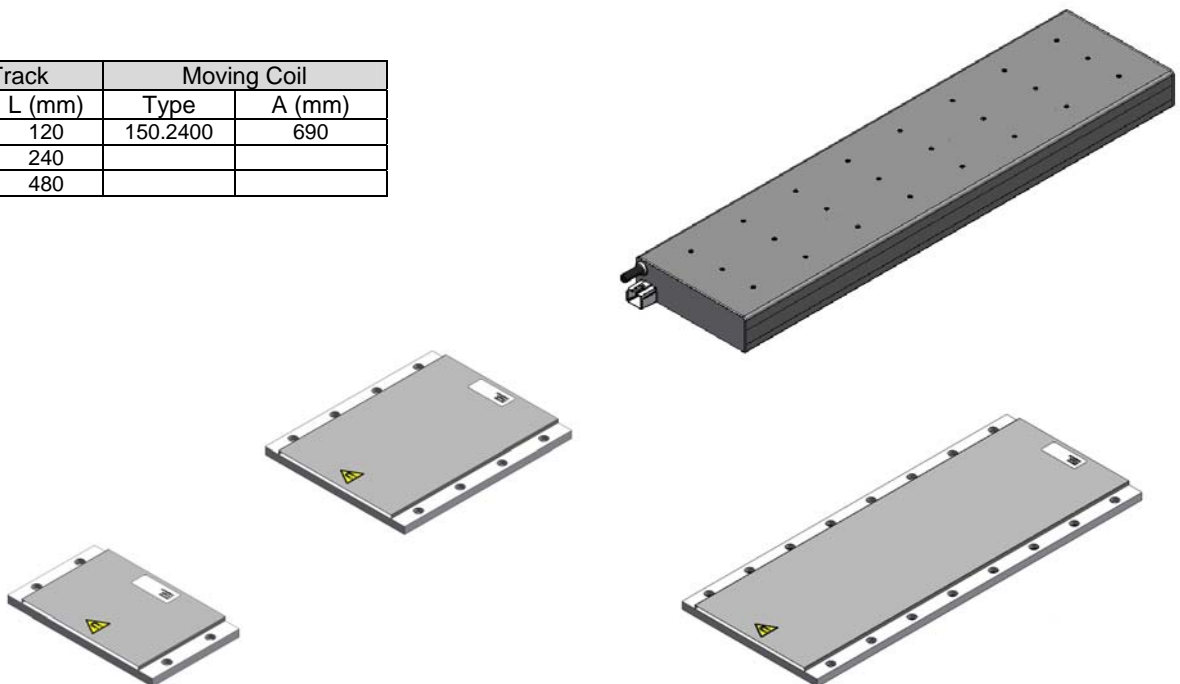

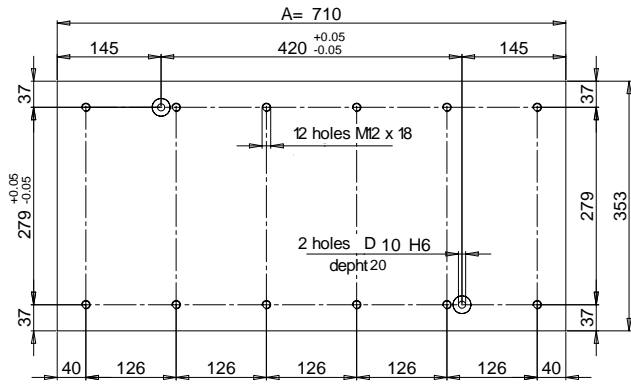

SKA DDL 150.2400

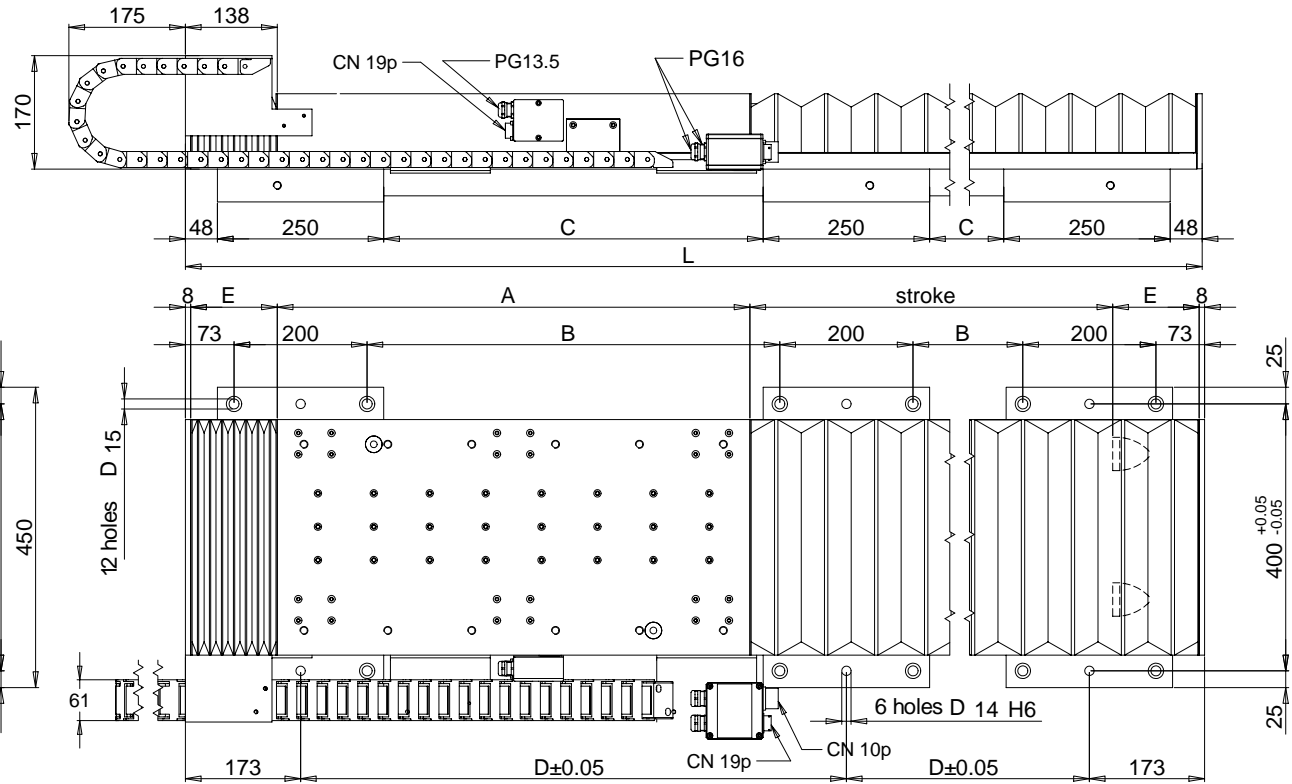
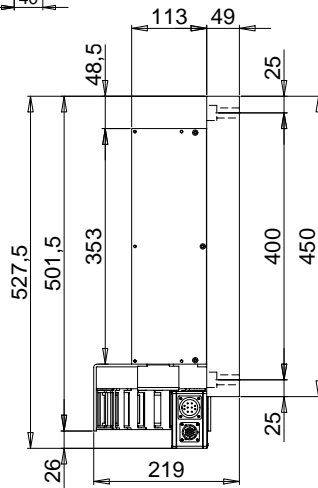

Series
SKA DDL 150.2400 *Linear Stage version*

Datasheet n°: SKADDL-2008-03-00

STROKE [mm]	500	700	1000	1200	1500	1800	2000	2500	3000
TYPE SKA DDL	150.2400	150.2400	150.2400	150.2400	150.2400	150.2400	150.2400	150.2400	150.2400
L	1486	1686	1986	2246	2606	2986	3226	3826	4446
A	710	710	710	710	710	710	710	710	710
B	370	470	620	750	930	1120	1240	1540	1850
C	320	420	570	700	880	1070	1190	1490	1800
D	570	670	820	950	1130	1320	1440	1740	2050
E	130	130	130	160	190	230	250	300	360

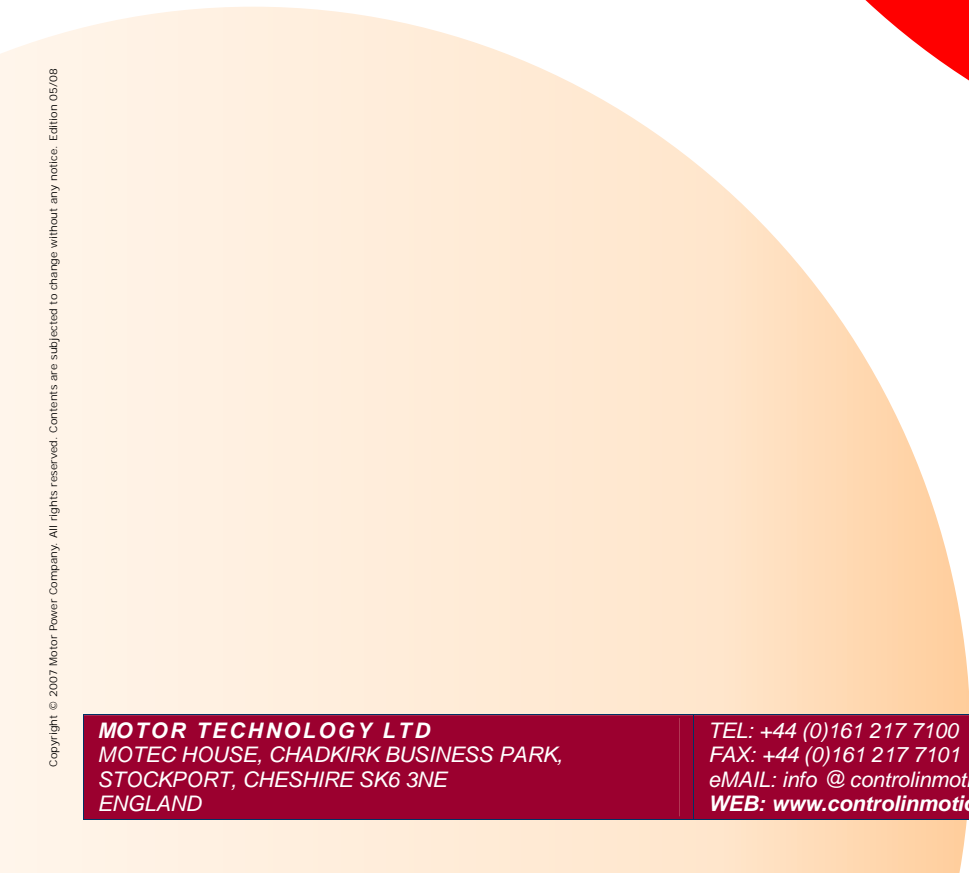
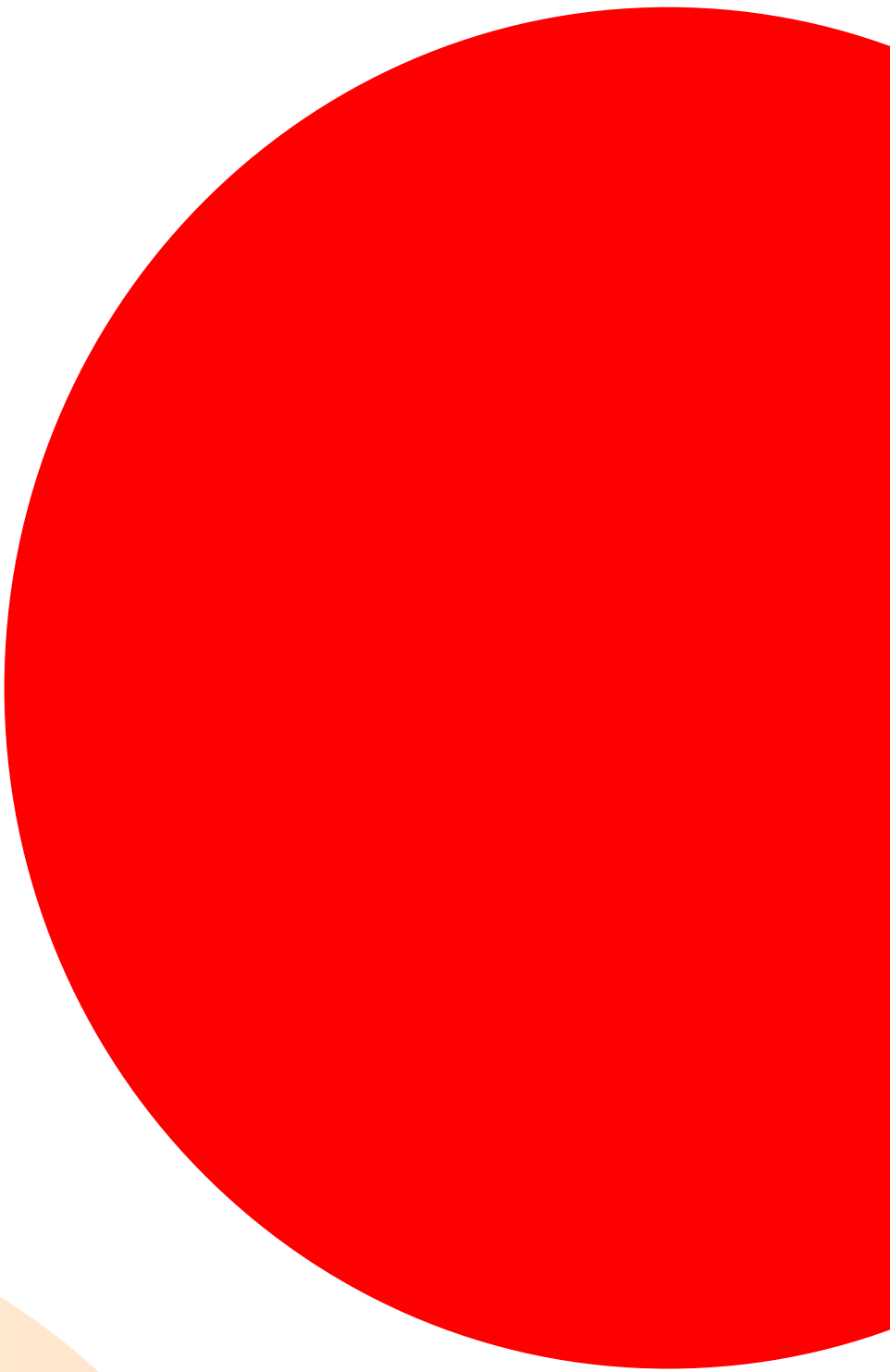

www.motorpowergroup.com

MOTOR TECHNOLOGY LTD
MOTEC HOUSE, CHADKIRK BUSINESS PARK,
STOCKPORT, CHESHIRE SK6 3NE
ENGLAND

TEL: +44 (0)161 217 7100
FAX: +44 (0)161 217 7101
eMAIL: [info @ controlinmotion.com](mailto:info@controlinmotion.com)
WEB: www.controlinmotion.com

